

FREECURVE | USER MANUAL



UK

Plus
Classic
Elegance
Alliance

CONTENT

FOREWORD

USER MANUAL	2
OPTIONS	12
IMPORTANT INFORMATION	16
FAULT FINDING	21
ATTACHMENTS	25
<i>A. Reminders</i>	<i>25</i>
<i>B. Remote control</i>	<i>26</i>
<i>C. Tap 2 floor</i>	<i>27</i>
<i>D. Record of contact names</i>	<i>28</i>

Thank you for choosing a Handicare stairlift. This manual is for the Plus, Classic and Elegance/Alliance seat types, and includes instructions for the standard features and optional upgrades.

Make everyday life easier...

PLUS

OPTIONS

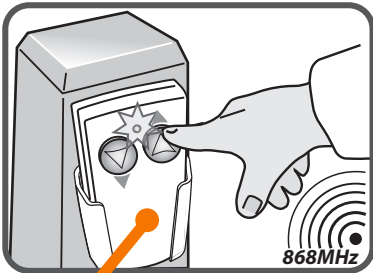
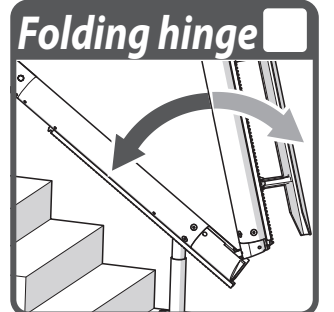

7

1

2

3

4

5

6

The illustration opposite shows the features used to operate the Plus seat. The Plus seat can be upgraded with a hinged rail, making it more user-friendly.

[1] LED
[2] Joystick
[3] Key switch
[4] Seat belt

[5] Seat swivel lever
[6] Footplate
[7] Remote control

CLASSIC

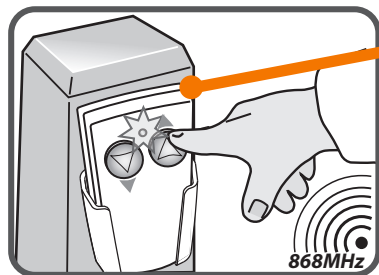

8

1

2

3

4

5

6

7

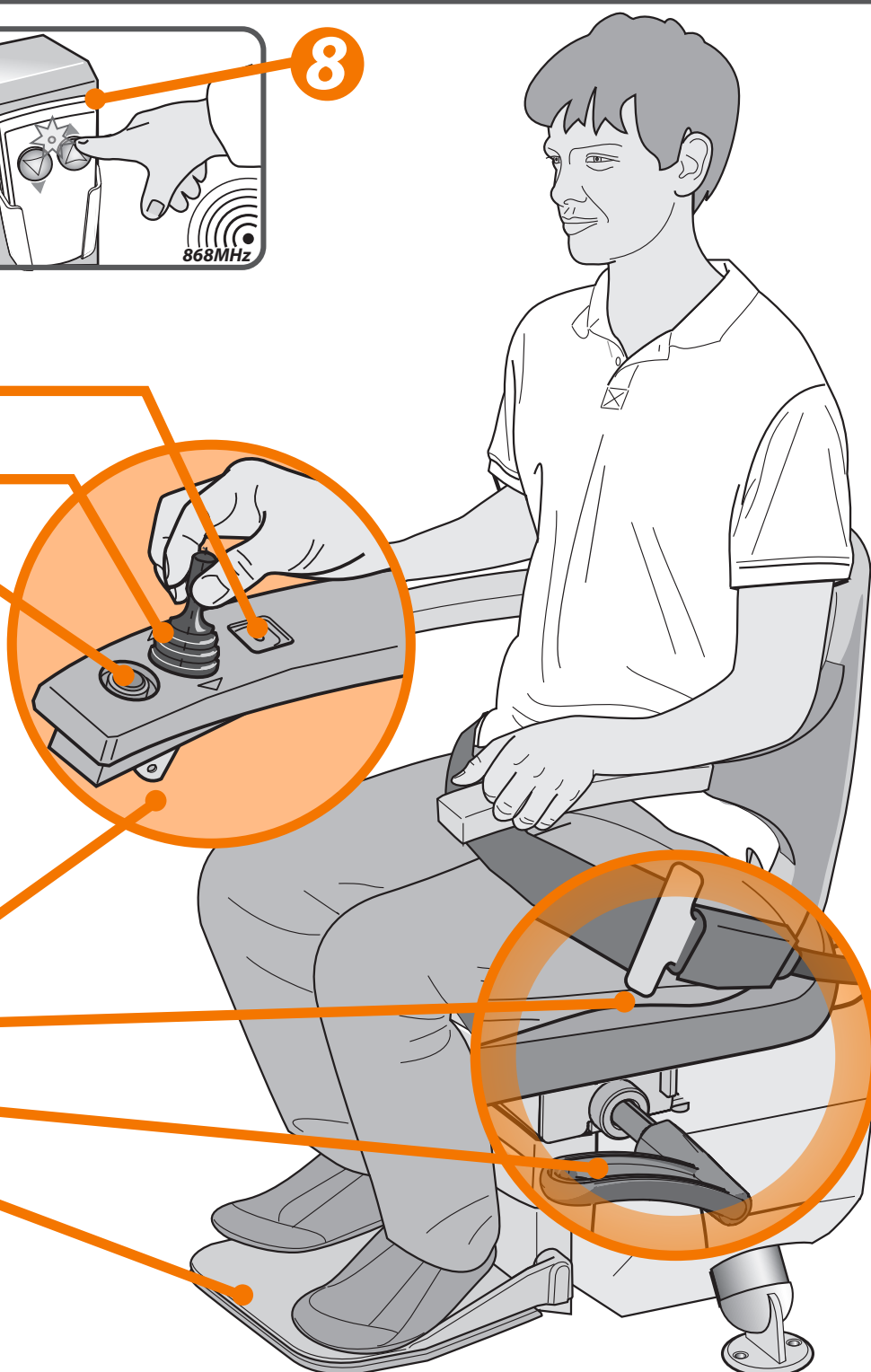

OPTIONS

Autoswivel



Pow. footrest

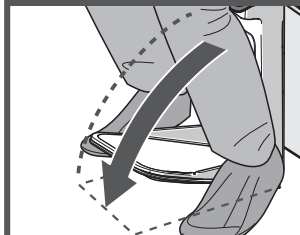

Folding hinge

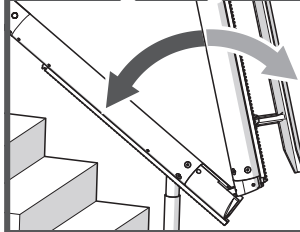

Turn & Go

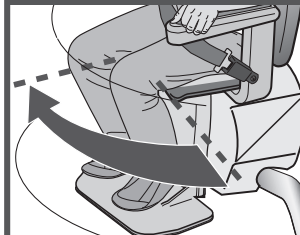

VoiceConnect

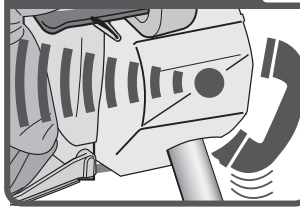

The illustration opposite shows the features used to operate the Classic seat. The Classic can be upgraded with the automatic swivel seat, powered footrest, hinged rail, Voice Connect and Turn & Go options to create even more seat comfort and user-friendliness.

- [1] LED
- [2] Joystick
- [3] Emergency stop
- [4] Key switch
- [5] Seat belt

- [6] Seat swivel lever
- [7] Footplate
- [8] Remote control

ELEGANCE / ALLIANCE

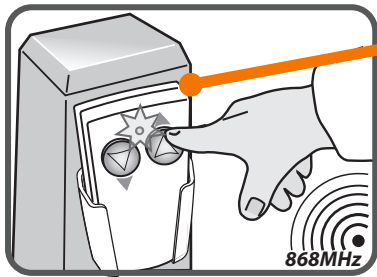

8

1

2

3

4

5

6

7

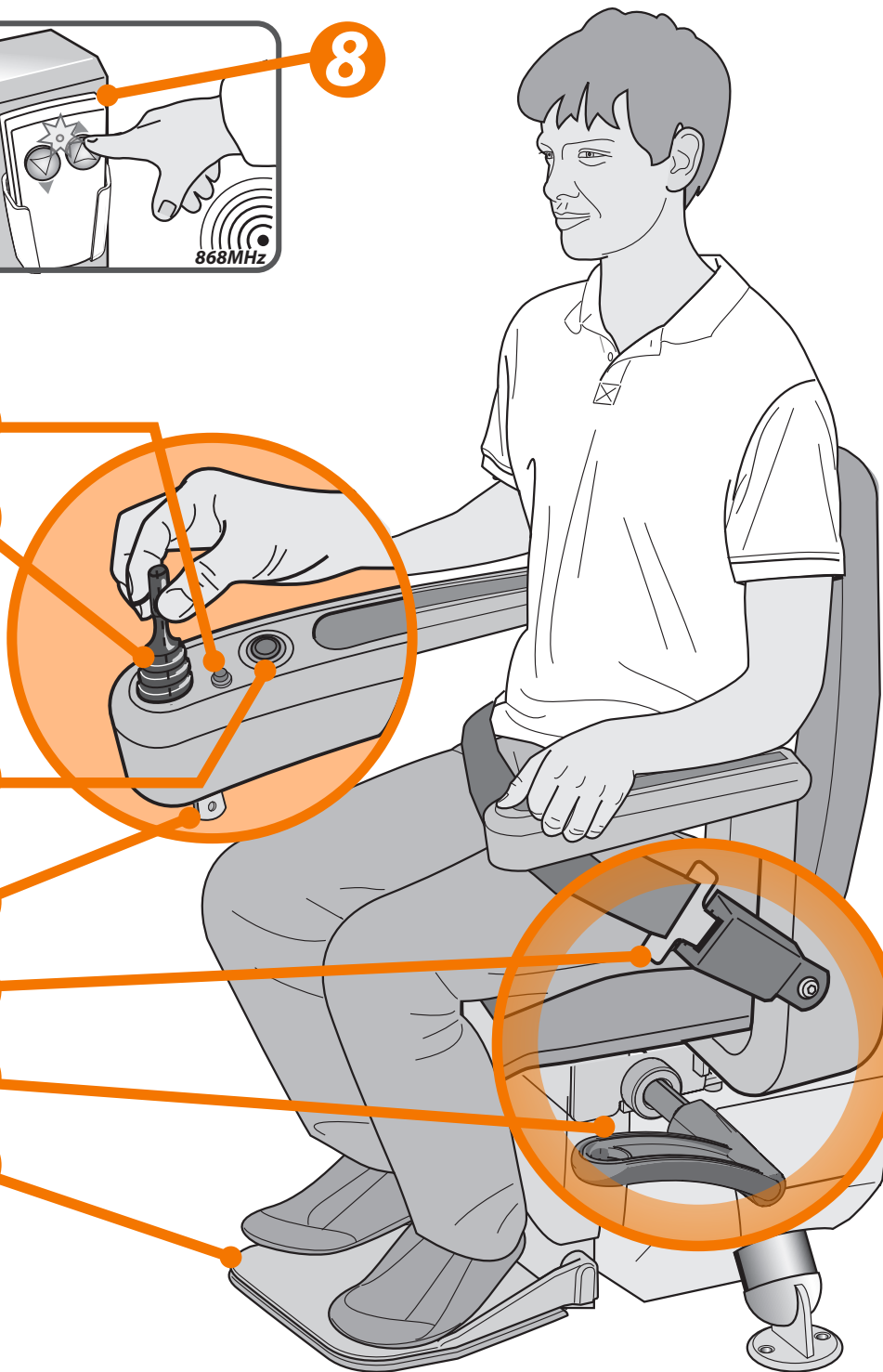

OPTIONS

Autoswivel



Pow. footrest



Folding hinge

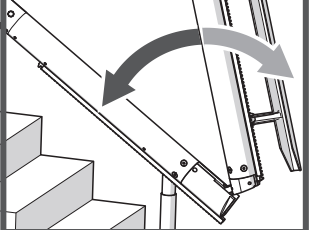

Turn & Go

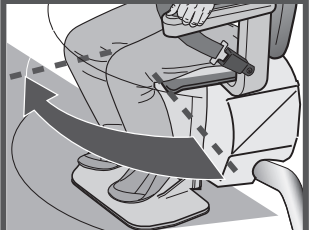

VoiceConnect

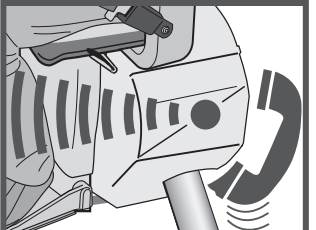

ActiveSeat

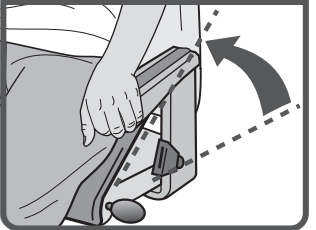

The illustration opposite shows the features used to operate the Classic seat. The Classic can be upgraded with the automatic swivel seat, powered footrest, hinged rail, Turn & Go, Voice Connect and Active Seat options to create even more seat comfort and user-friendliness.

- [1] LED
- [2] Joystick
- [3] Emergency stop
- [4] Key switch
- [5] Seat belt
- [6] Seat swivel lever
- [7] Footplate
- [8] Remote control

FOLD DOWN

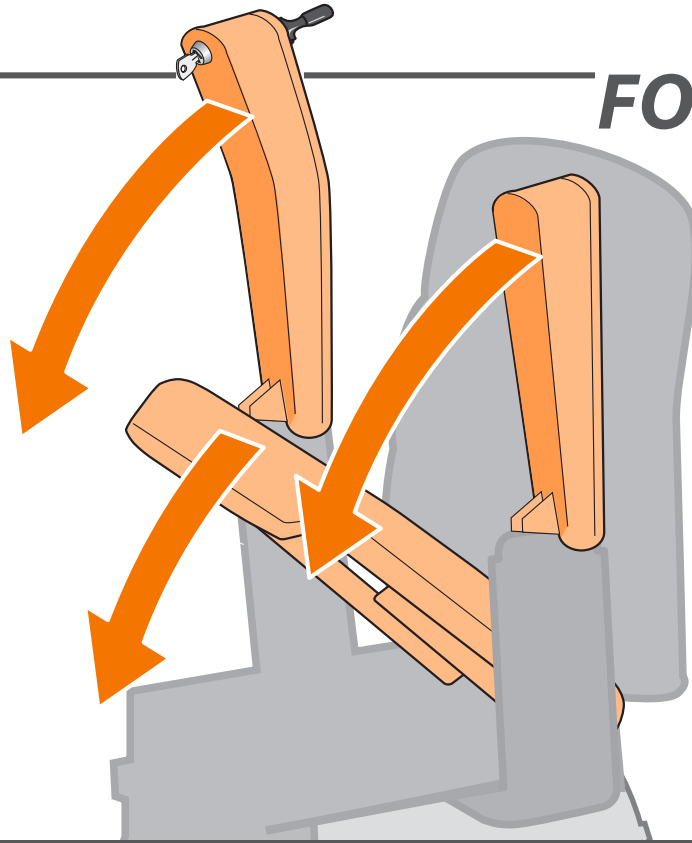

Fold down the armrests and seat.

SIT DOWN

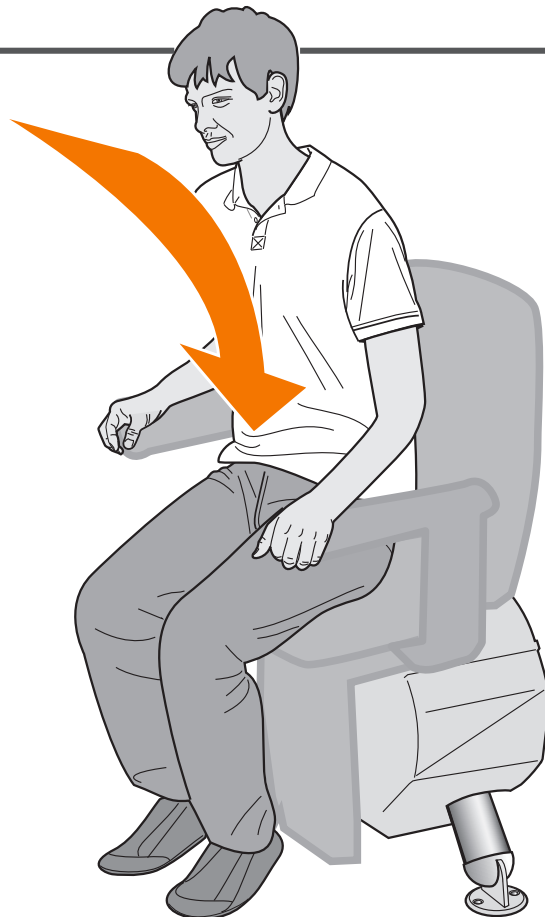

Sit down on the seat.



page 15 > OPTIONAL ACTIVE SEAT

UNFOLD FOOTREST

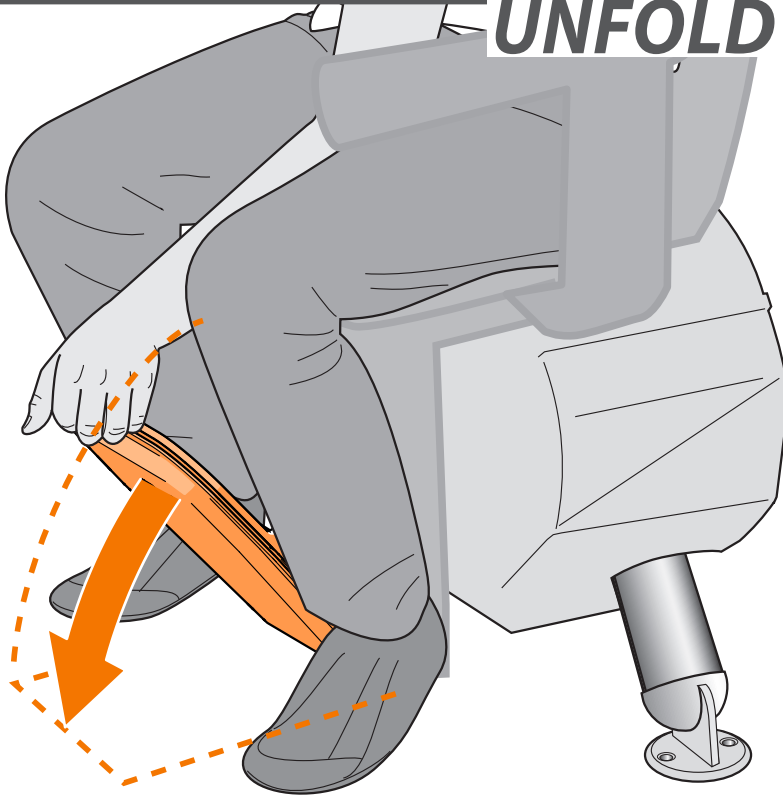

Fold down the footplate.



page 13 > OPTIONAL POWERED FOOTREST

PLACE FEET

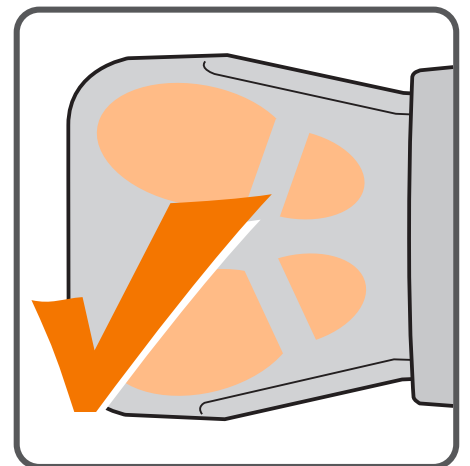
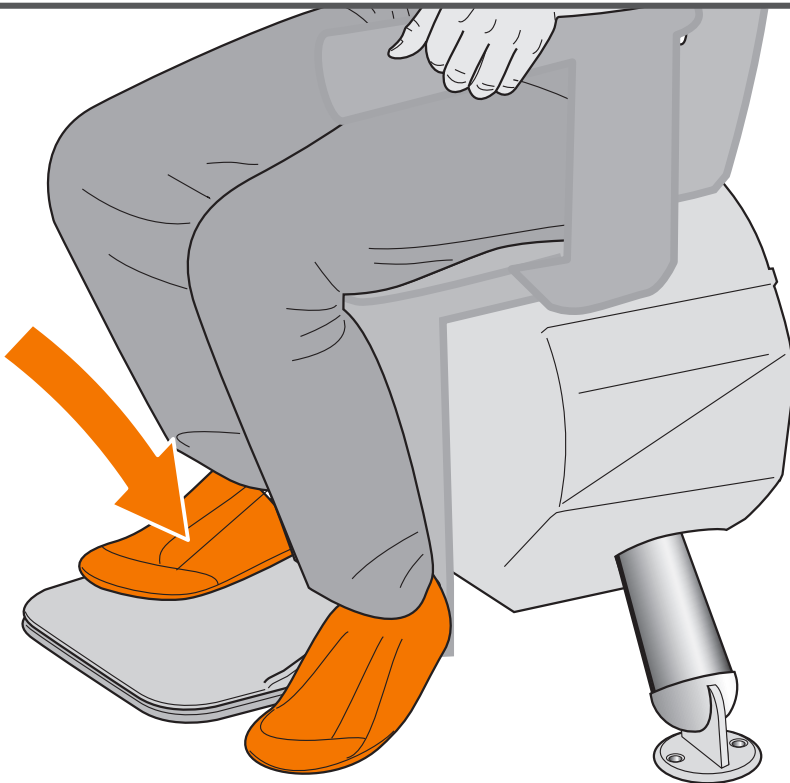

Place your feet on the footplate. Ensure that both feet are completely on the plate.

SAFETY FIRST

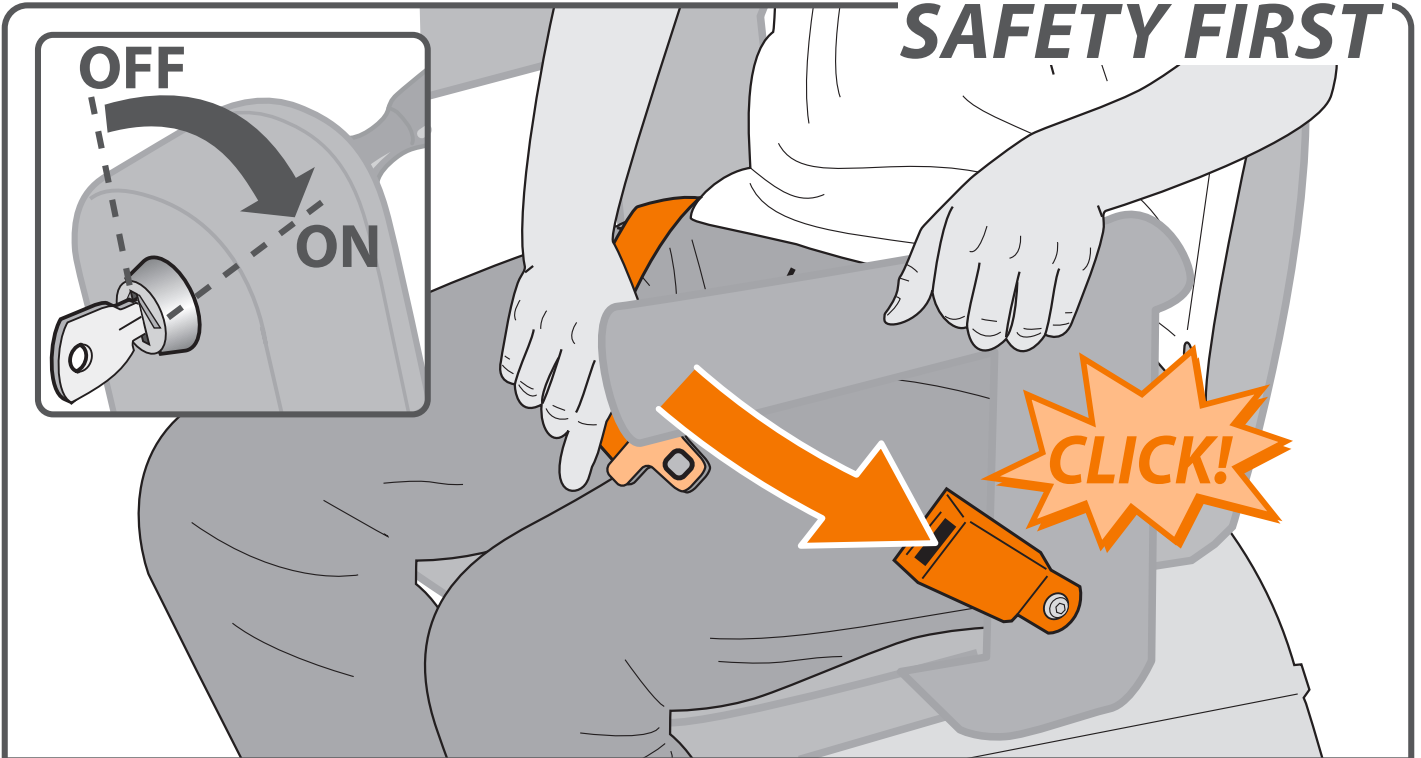

Fasten the seat belt securely, ensuring that it clicks into the holder. Put the key in the switch and turn it ninety degrees clockwise. The LED on the armrest lights up faintly.

RIDE

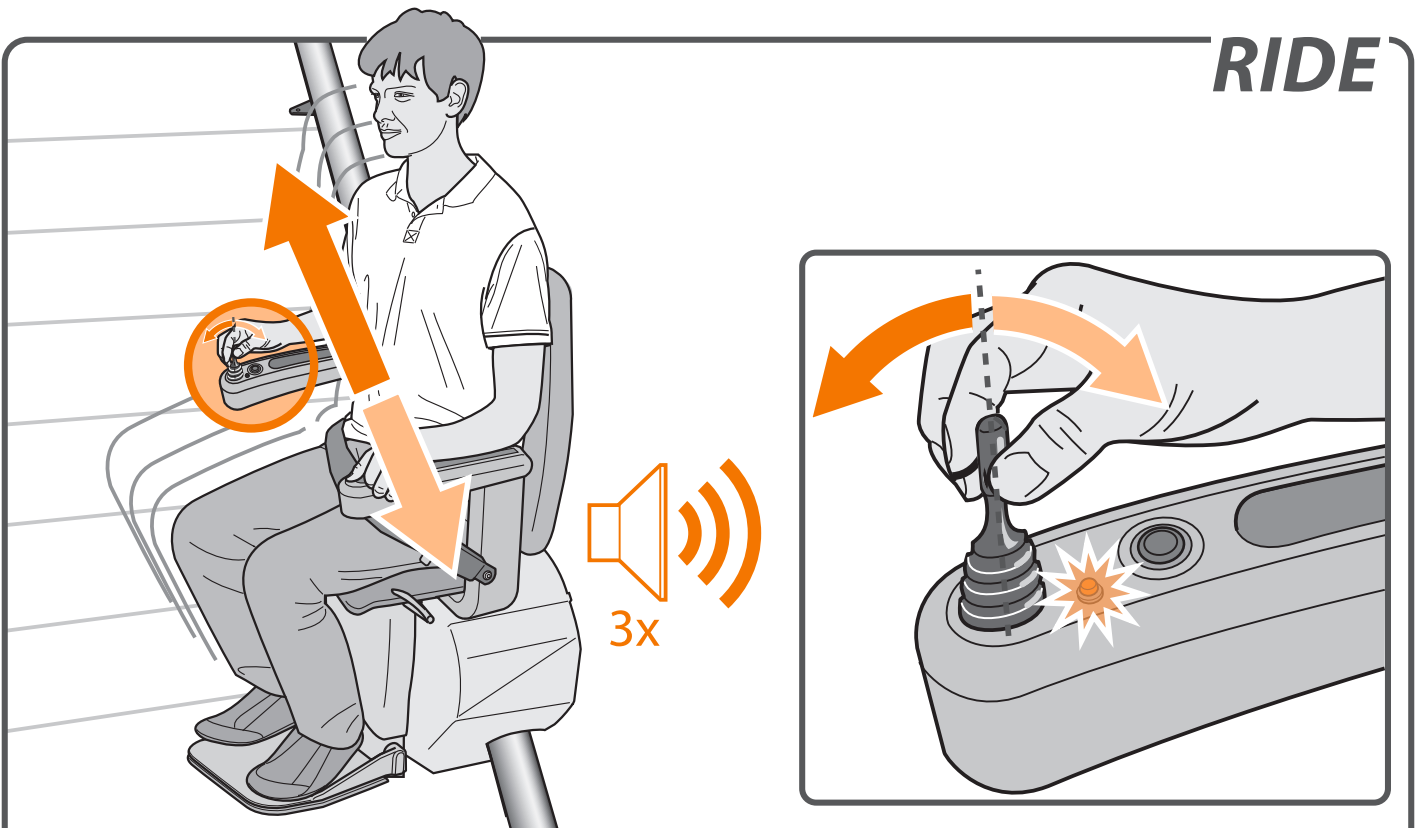

Move the joystick in the desired direction of travel. The LED lights up. The lift beeps three times, then gradually starts to move.

EMERGENCY STOP

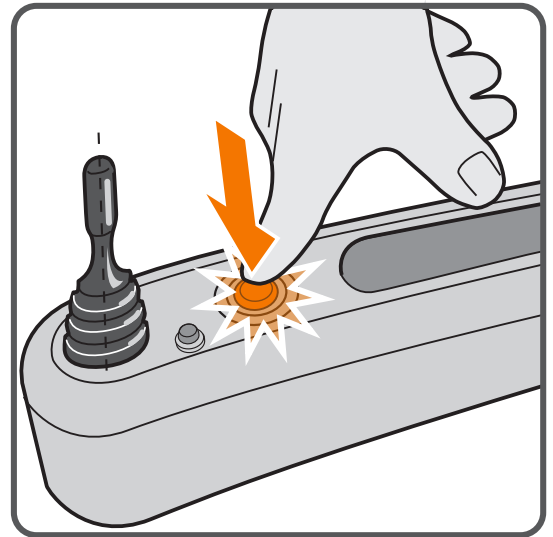

In an emergency, press the emergency stop once. The lift stops straight away. To release the lift, press the emergency stop again.

 page 15 > OPTIONAL VOICECONNECT

SWIVEL

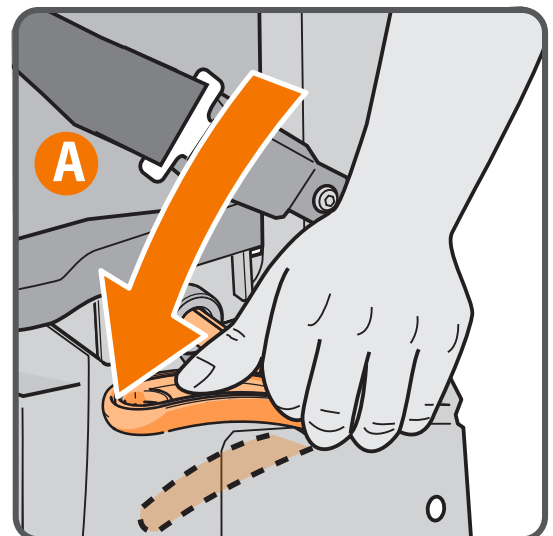
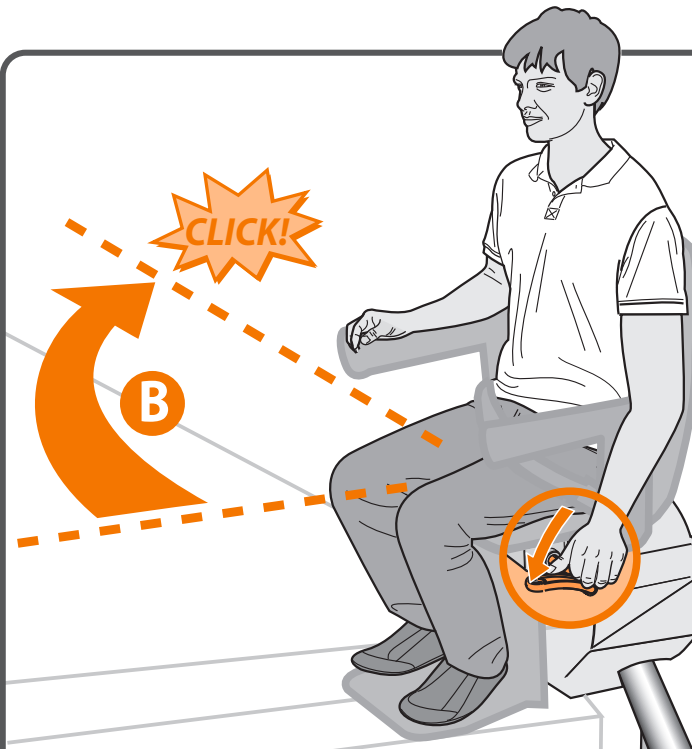

The lift stops automatically at the end of the rail. You can now swivel the seat manually, making it easier to get on and off. To do this, push down the lever{A}. Swivel the seat until you hear a 'click'. The seat is now in the correct position{B}.

 page 12 > OPTIONAL AUTOSWIVEL

FOLD FOOTREST

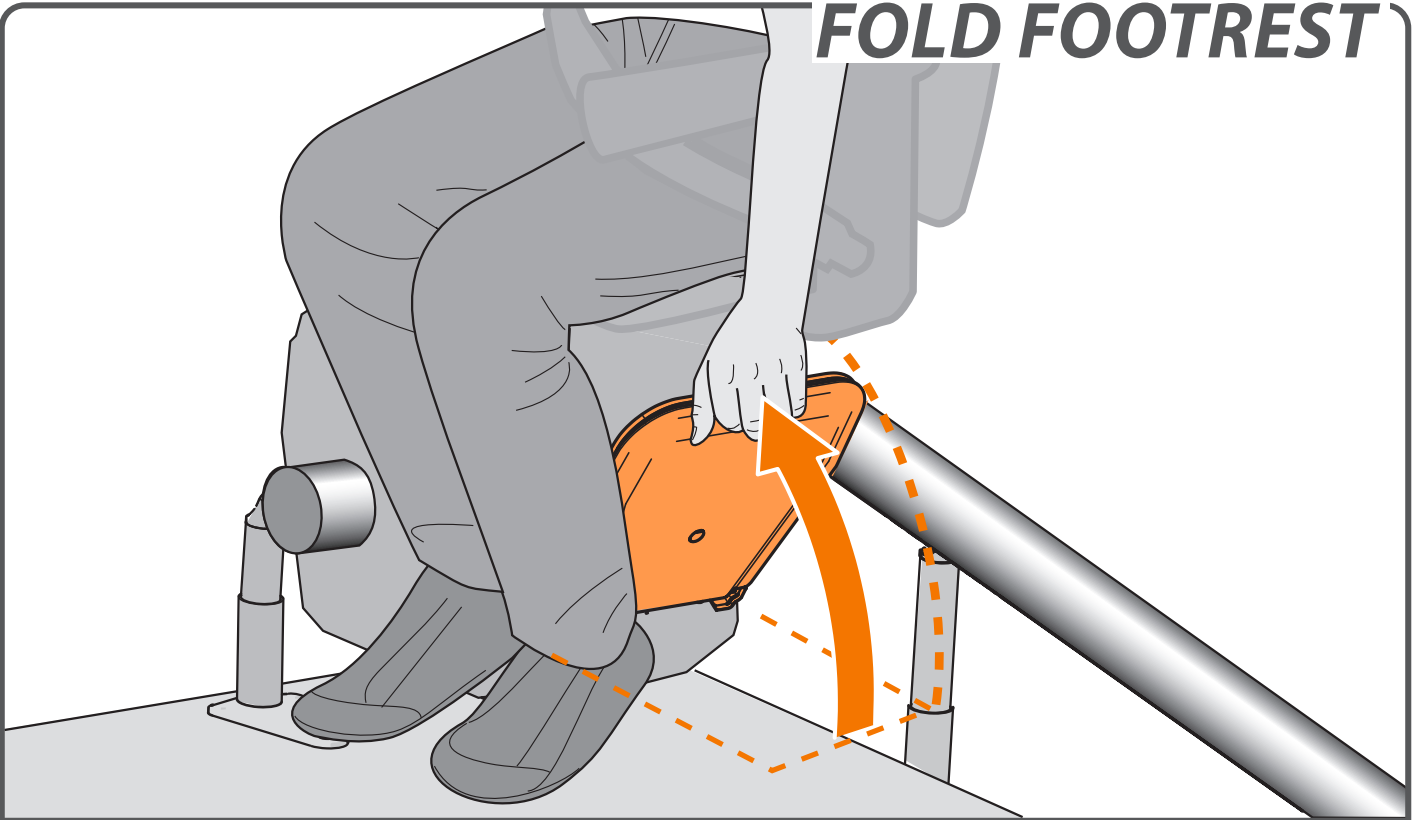

Fold up the footplate.



page 13 > OPTIONAL POWERED FOOTREST

LOOSEN BELT

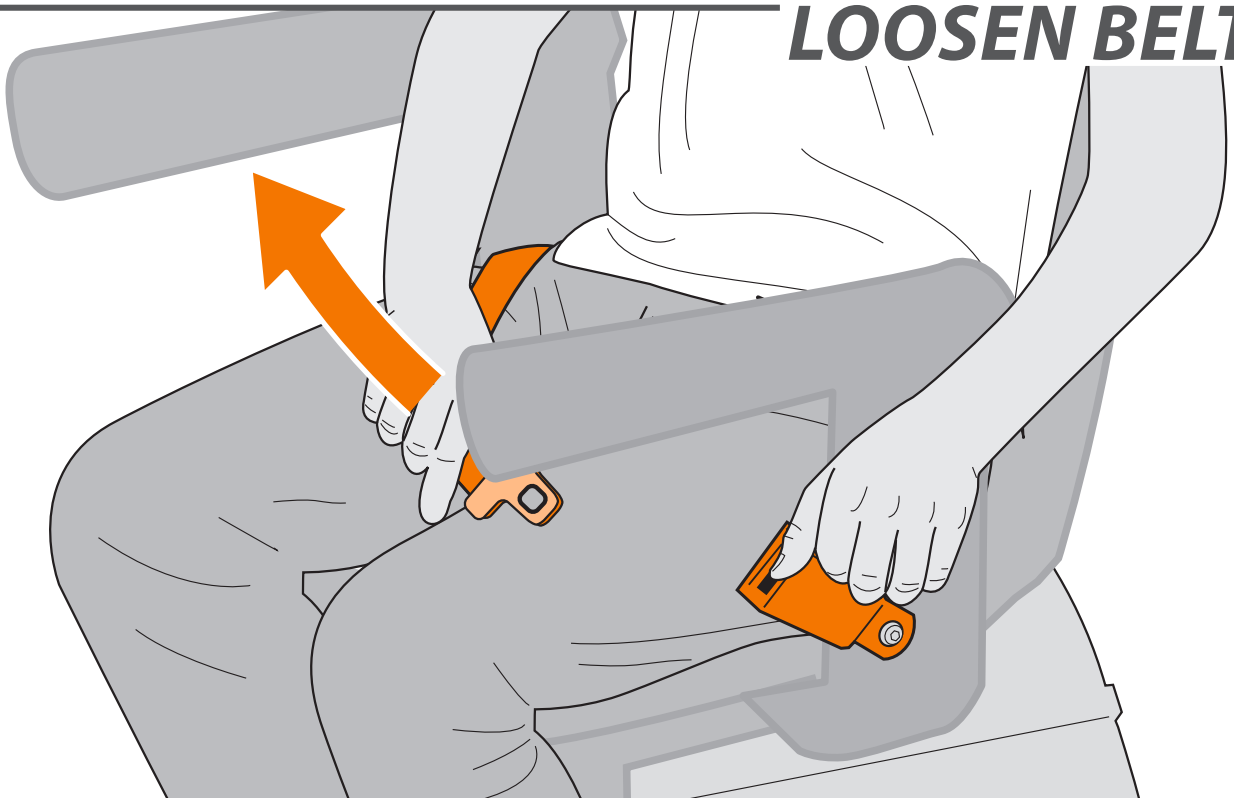

Unfasten the seat belt.

STAND UP



Stand up from the seat.



page 15 > OPTIONAL ACTIVE SEAT

FOLD UP

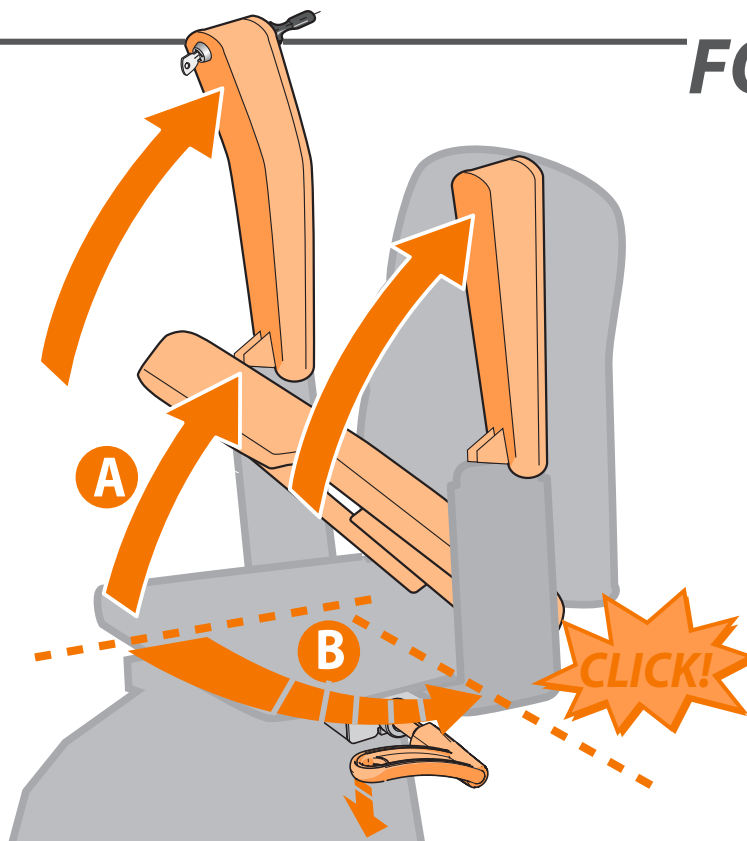
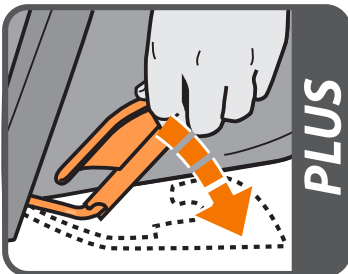

Fold up the armrests and seat {A}. Push the handle, located to the left or right under the seat, downwards. Swivel the seat until you hear a 'click'. The seat is now in the locked position {B}.

PARK

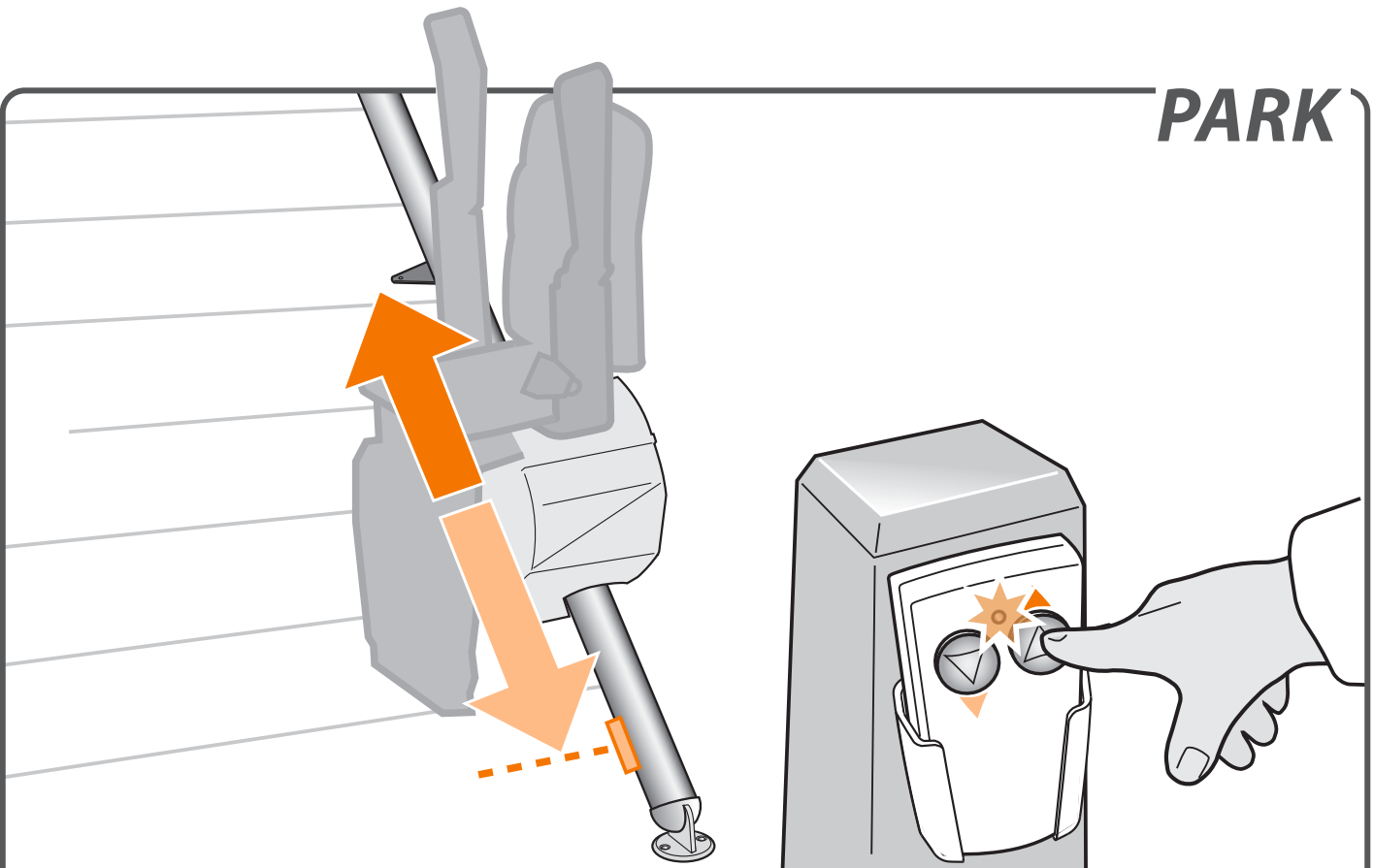

Press and hold the button on the remote control until the lift reaches a charge point. Upon arrival, the lift stops automatically and the LED on the remote control goes out.

CHARGE

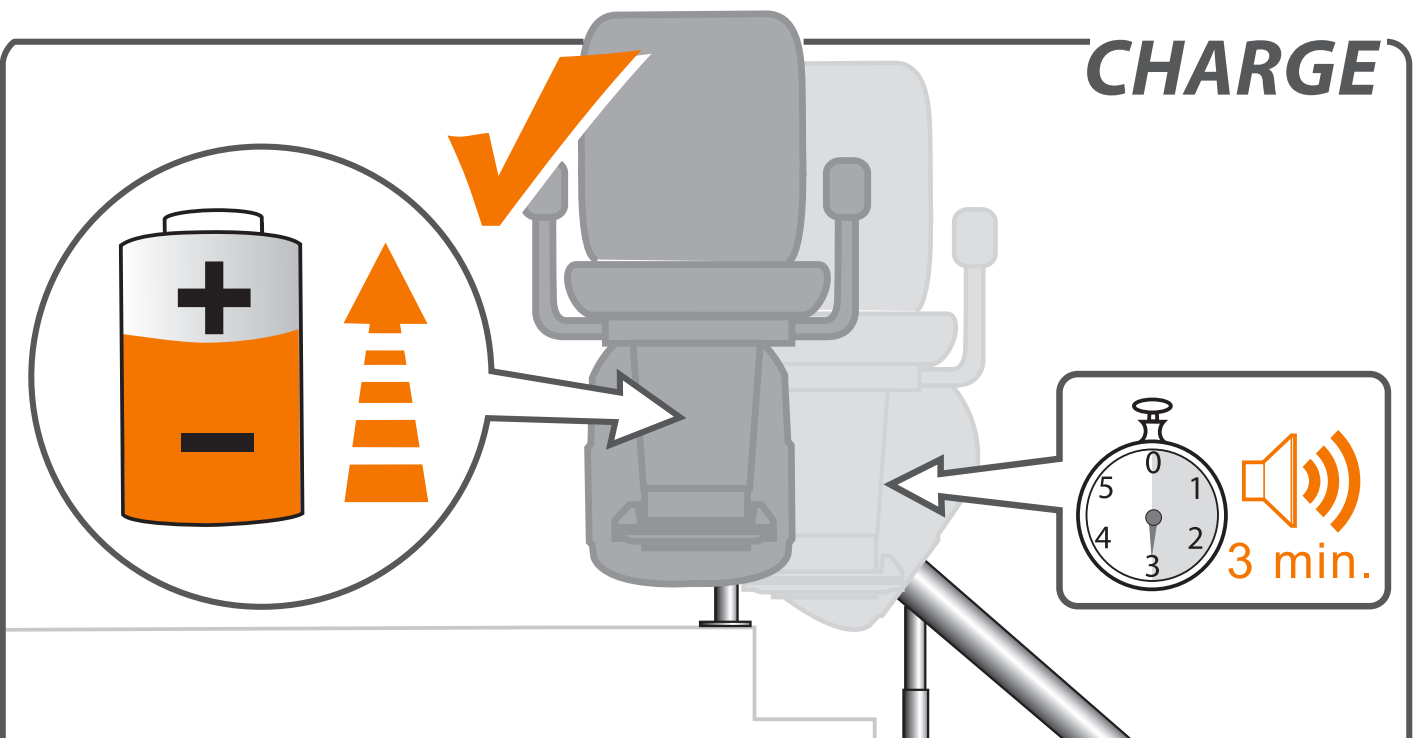

There are charge points for recharging the lift's batteries at the top and bottom of the rail (there may be additional charge points). If the lift is not in the correct position at the charge point, the lift beeps for three minutes and the LED in the armrest flashes. The lift does not work if the batteries are flat.

OPTIONS

AUTOSWIVEL _____ *page 12*

POWERED FOOTREST _____ *page 13*

FOLDING HINGE _____ *page 13*

TURN & GO _____ *page 14*

VOICE CONNECT _____ *page 15*

ACTIVE SEAT _____ *page 15*

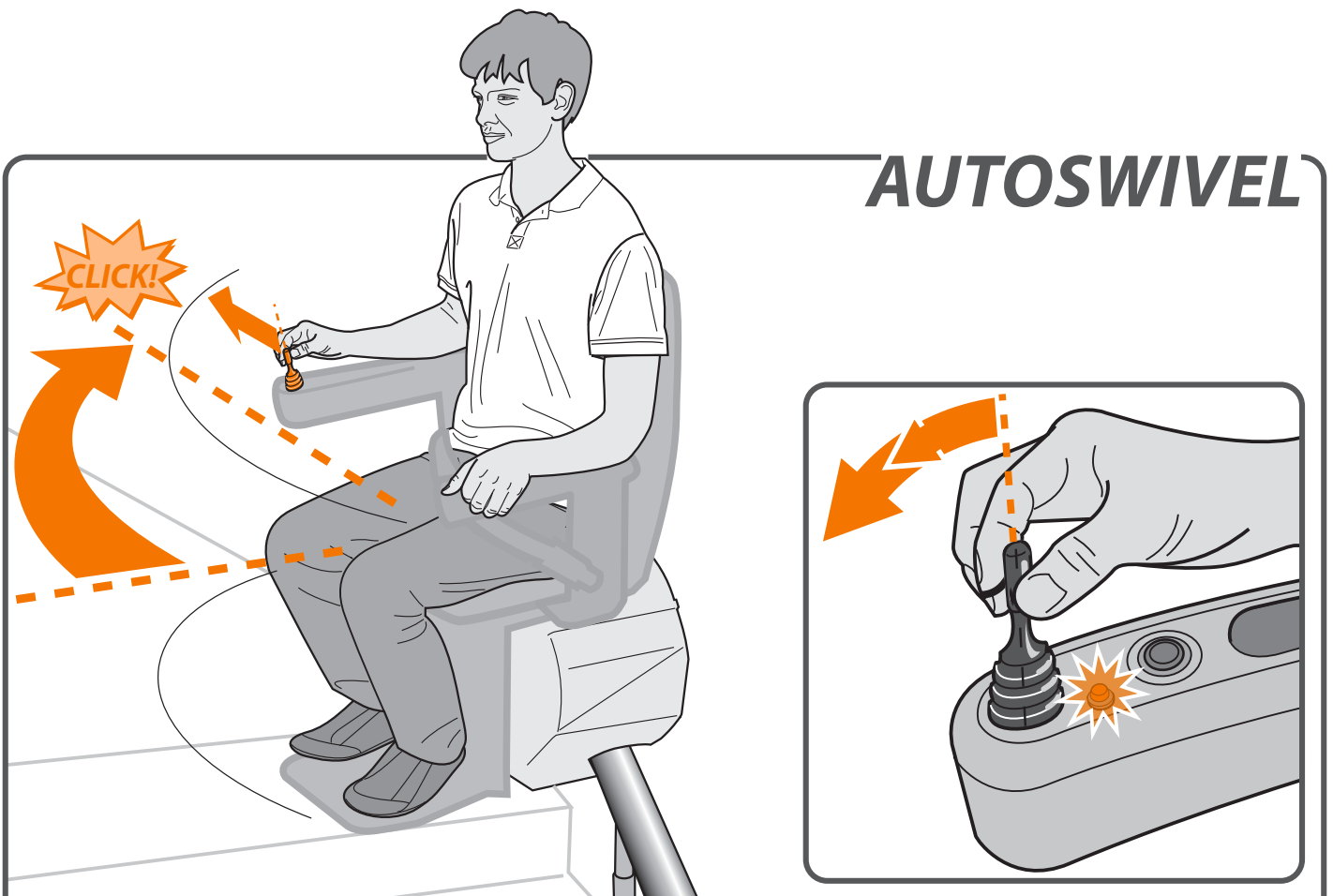

The AUTOMATIC SWIVEL SEAT option lets you swivel the seat automatically to face the direction you are going to walk in. To do this, push and hold the joystick in the upwards direction.

POWERED FOOTREST

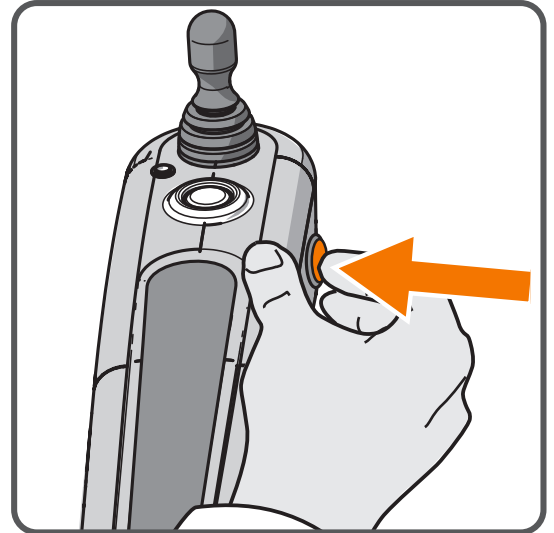

The POWERED FOOTPLATE option lets you fold the footplate up and down automatically using the switch on the side of the armrest. The footplate lights up when folded down.

FOLDING HINGE

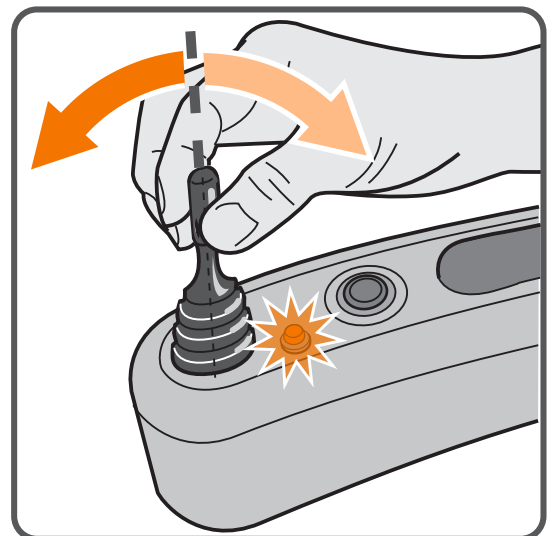
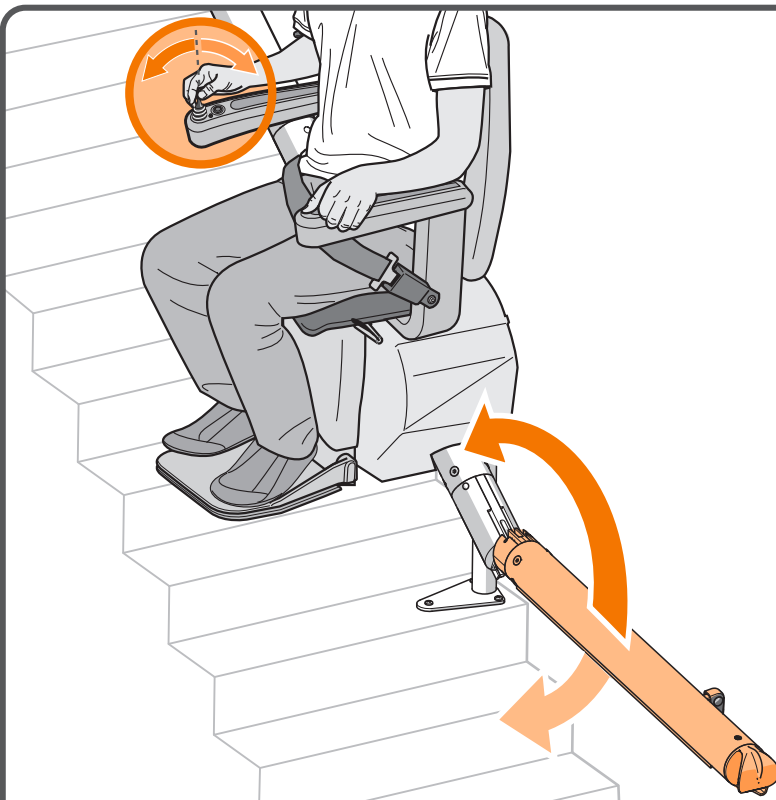

With the FOLDING HINGE option, the seat stops just above the hinged rail. Move the joystick up or down to fold or unfold the rail.

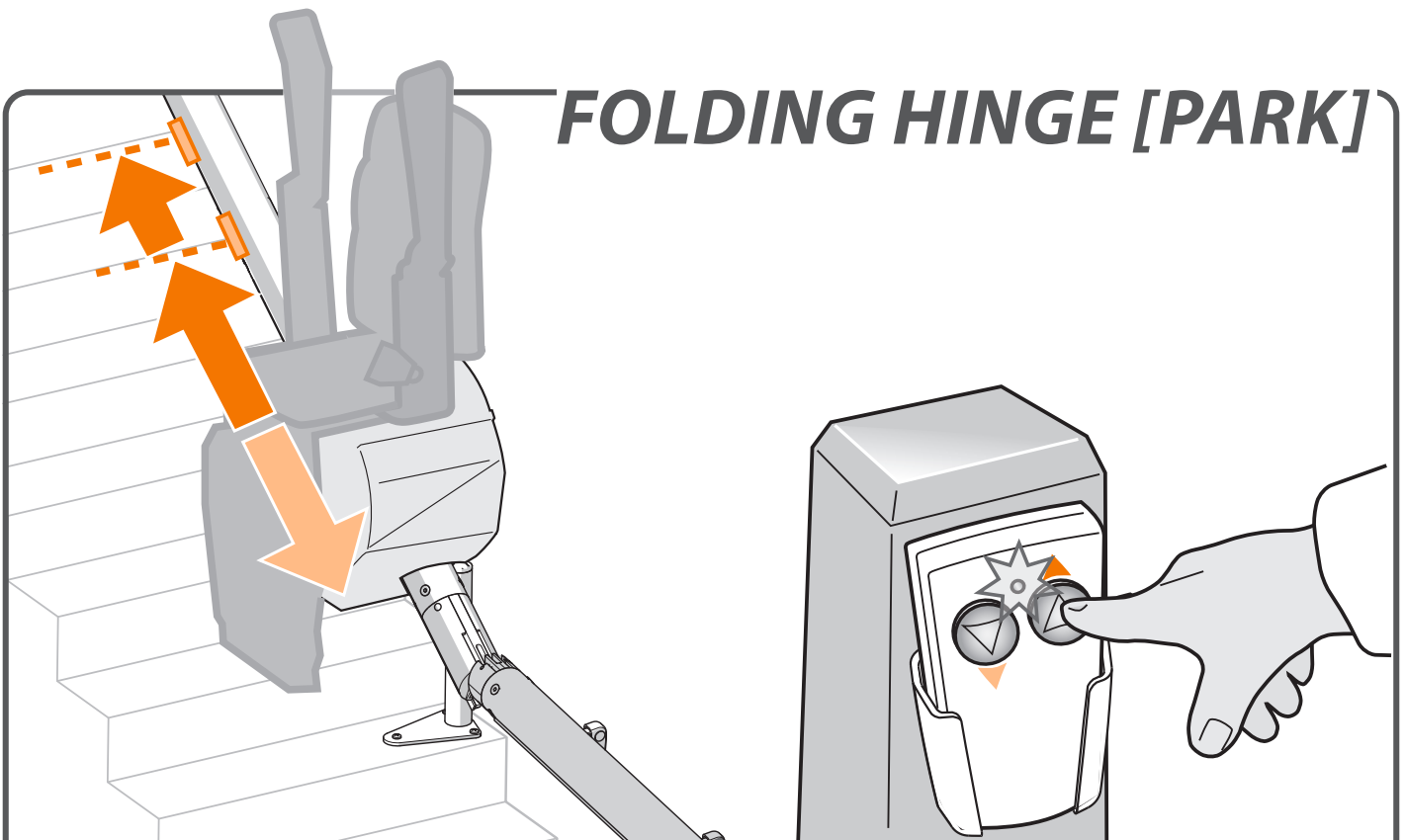

FOLDING HINGE [PARK]

Do not leave the lift on the hinged rail after use. Use the remote control to move the lift to a charge point and recharge the batteries. The first stopping point is at the hinged rail. Keep moving the lift until it reaches a charge point further up.

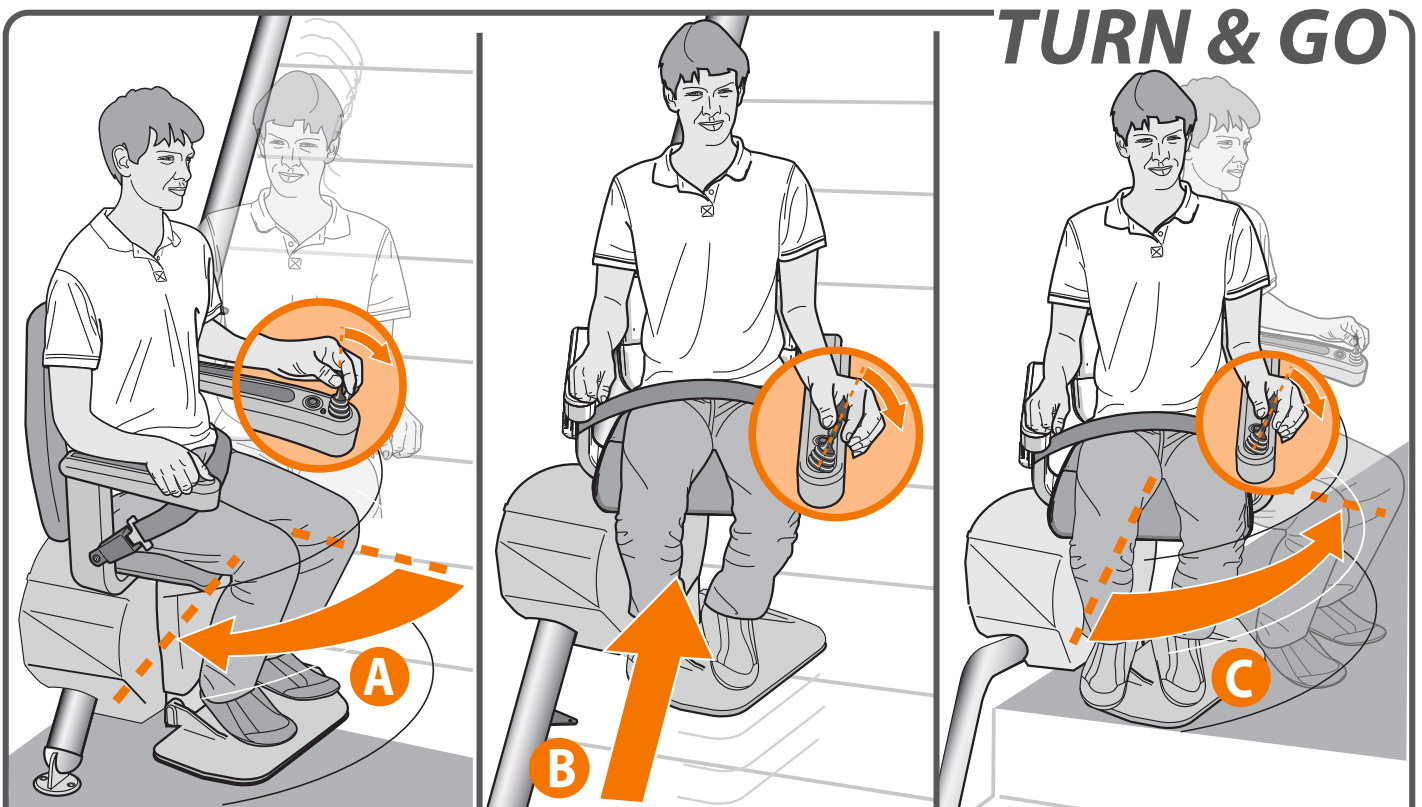

TURN & GO

The TURN & GO option swivels the seat so that you travel up and down with your back to the stairs {B}. Hold the joy stick in the desired direction of travel, at the start and end of the rail {A and C}.

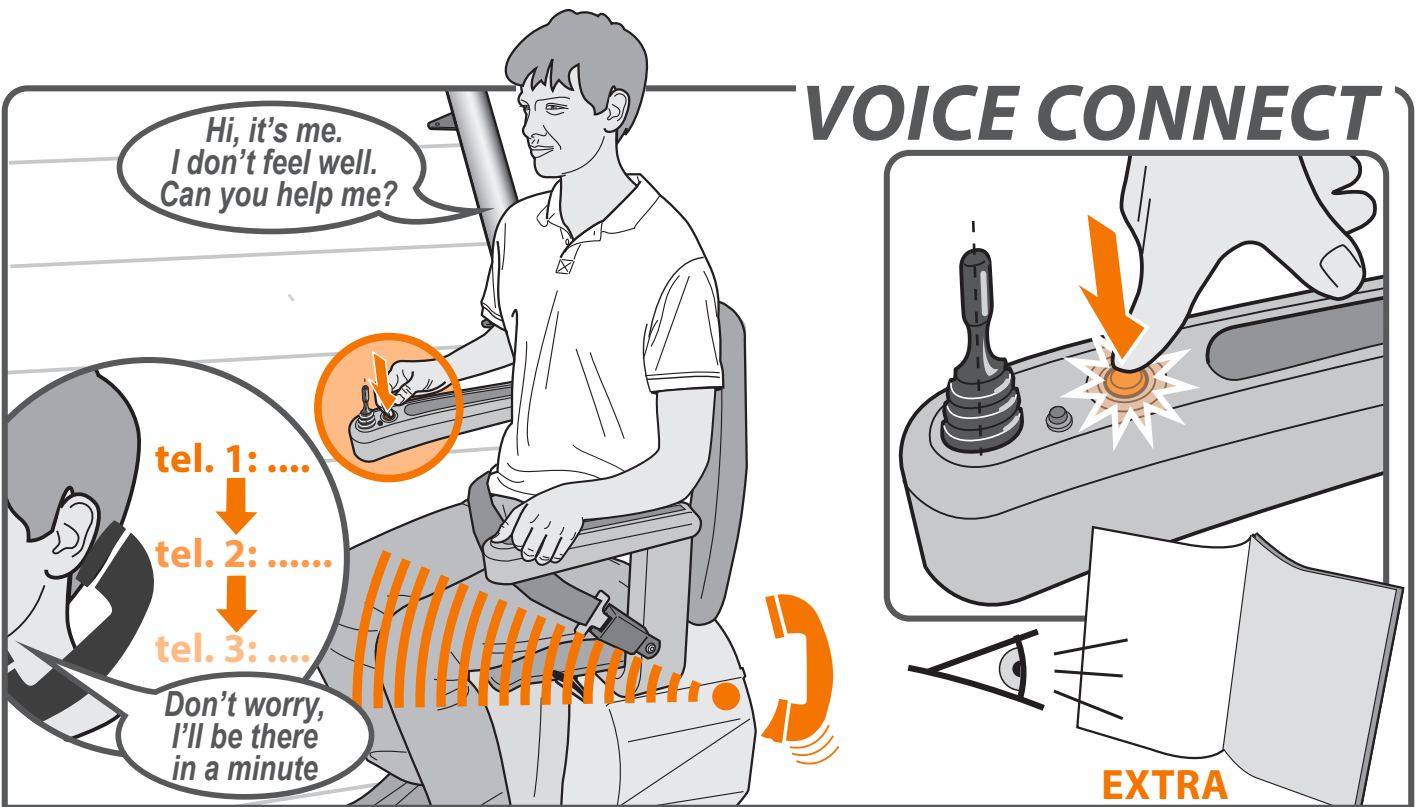

The VOICE CONNECT option lets you call one of the three telephone numbers you have chosen, by pressing the red button. Check once a month that the Voice Connect function is working correctly. For more details, please read the separate Voice Connect documentation.

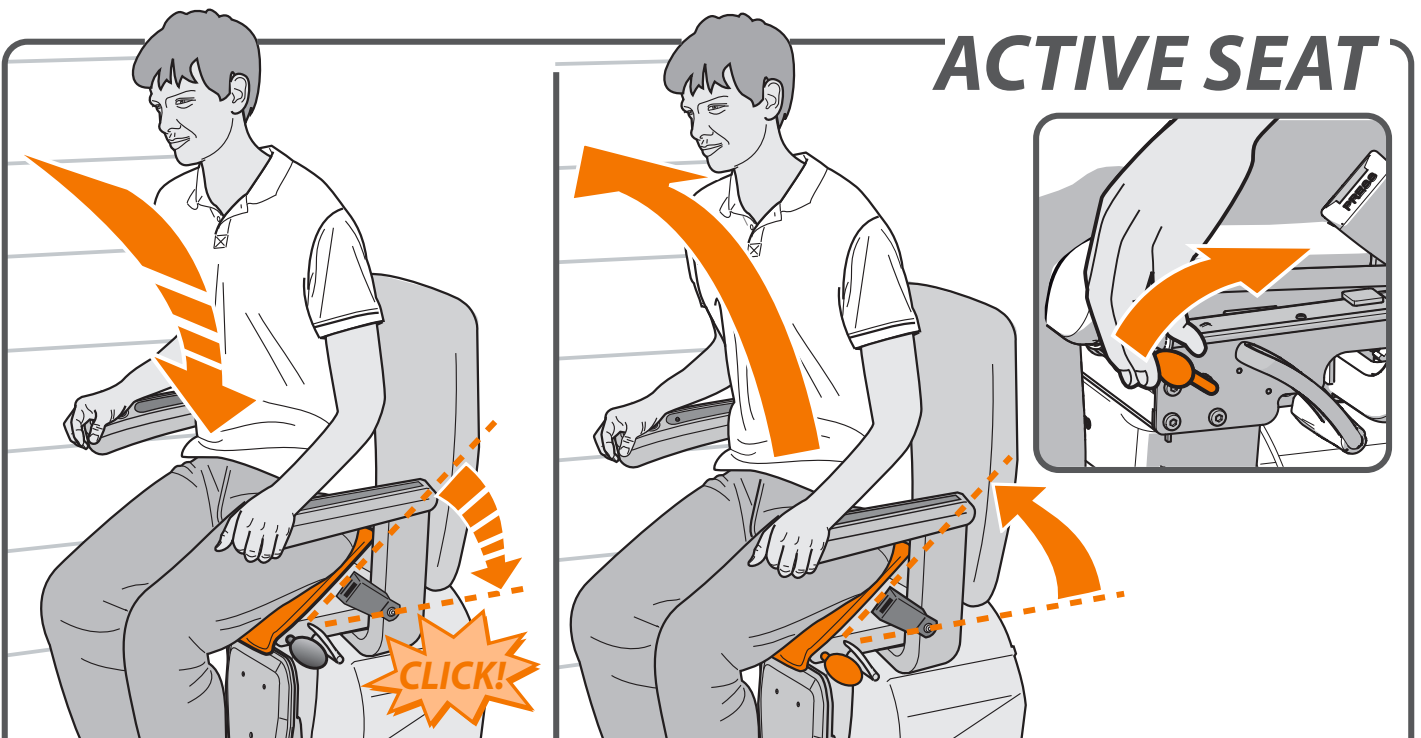

With the ACTIVE SEAT option, the seat assists you when sitting down and standing up. To stand up, pull the handle, located to the left or right under the seat, upwards. The seat pushes you up. When you sit back down, the seat slowly returns to its normal position and clicks into place. The lift will not move until the seat is securely clicked in place.

IMPORTANT INFORMATION

EG DECLARATION OF CONFORMITY FOR MACHINERY

(Directive 2006/42/EG)

Manufacturer: Handicare
Address : Newtonstraat 35
1704 SB Heerhugowaard
Postbus 39
1700 AA Heerhugowaard
Holland
Tel.nr. +31 (0)72-5768888

Herewith declares that the

Van Gogh / Rembrandt / Vermeer

is in conformity with the provisions of the Machinery Directive 2006/42/EG, Low Voltage Directive 2006/95/EC and EMC Directive 2004/108/EC.

The stairlifts are 24V DC Powered Stairlifts moving in an inclined plane, used with an approved battery charger product.

The stairlift has been designed and manufactured in accordance with the following standards:

EN 81-40, ISO 9386-2, EN ISO 12100-1,
EN ISO 12100-2, EN ISO 14121,
EN60204-1, (including the EMC standards).

Liftinstituut B.V., Buikslotermeerplein 361, 1025 XE, Amsterdam, The Netherlands. Identificationnr 0400 has issued an EC-certificate in compliance with above mentioned directives and standards with reference NL02-400-1001-015-006.

The Technical Construction File for the above Stairlift is retained at the manufacturers address. A copy is retained at the Liftinstituut B.V.office.

Heerhugowaard, The Netherlands, 1 january 2013



J.W.F. Meier
Managing Director Handicare b.v.

Project:

Date:

FOREWORD

Your stairlift is a sophisticated stairlift, specifically developed to carry one person sitting on the chair up to a maximum weight of 125 kg. The information provided in properties and working methods known to us at the time of publication; alterations and any improvements are therefore excepted. Before using the stairlift read this manual thoroughly and familiarise yourself with the working and operation of the stairlift. Your stairlift has been constructed in accordance with state-of-the-art technology and satisfies recognized safety regulations. Nevertheless during the wrong use of the stairlift risk to the user or third parties, or damage to your stairlift or other goods, can arise. So use your stairlift only when it is in good working order, in accordance with the intended use described above and with due attention to this manual. Always keep this manual in the vicinity of the stairlift.

The strength and the suitability in general of wall, staircases, terraces, upper floors, banisters, plinths etc. which are to support or surround the installation have been verified and ensured by the customer, who therefore accepts all relative responsibilities. Neither Handicare nor its authorized dealers may be held responsible for the suitability of the structures which surround and support the installation. All tests, except for the operating test, shall be performed by the customer.

TECHNICAL SUPPORT

Should problems occur that are not dealt with in this document, contact your supplier. The Service department staff will always be pleased to help you. For quick handling it is important that you keep the following items/particulars to hand:

- this manual;
- your name, address, postcode, town and telephone number;
- lift number.

GUARANTEE AND LIABILITY

As the user of this stairlift, you are always fully responsible for the observance of locally prevailing safety regulations and guidelines. The manufacturer guarantees that this stairlift (excluding batteries) will be repaired free of charge should manufacturing and/or material defects occur within 24 months of the purchase date, during normal use in accordance with the recommended user, installation and maintenance instructions. Excluded from guarantee: damage caused by normal wear and tear, overloading or misuse, the replacement of batteries in the remote control. Under no circumstances can the manufacturer accept responsibility for death, personal injury, damage to property, or incidental, unforeseen consequences and/or costs or damage resulting from the use of your stairlift. The carrying out of alterations to the product is not permitted. The manufacturer is not liable for damage resulting from such alterations. The manufacturer accepts no liability for damage or injury caused by the non-observance, or inadequate observance, of the safety regulations and safety instructions in this manual, or by negligence during the installation, use, maintenance and repair of this stairlift. Installation and servicing may

only be carried out under the responsibility of dealers or installers/service engineers authorised by the manufacturer, in the course of which locally prevailing regulations must be observed.

The wallbuttons of this stairlift work radiographic. Handicare does not accept any responsibility for the non-functioning of these wallbuttons due to interference by a source outside this stairlift.

This equipment has been tested and found to comply with the limits for a Class B digital device, pursuant to part 15 of the FCC Rules. These limits are designed to provide reasonable protection against harmful interference in a residential installation. This equipment generates, uses and can radiate radio frequency energy, and if not installed and used in accordance with the instructions, may cause harmful interference to radio communications. However, there is no guarantee that interference will not occur in a particular installation. If this equipment does cause harmful interference to radio or television reception, which can be determined by turning the equipment OFF and ON, the user is encouraged to try to correct the interference by one or more of the following measures:

- Reorient or relocate the receiving antenna.
- Increase the separation between the equipment and receiver.
- Connect the equipment into an outlet on a circuit different from that to which the receiver is connected.
- Consult the dealer or an experienced radio/TV technician for help.

SAFETY INSTRUCTIONS

When using the stairlift always observe locally prevailing safety regulations regarding risk of electric shock and physical injury.

- 1.** Provide an unobstructed environment. The entire track must be free of obstacles.
- 2.** Take environmental influences into account. Do not expose the lift to damp or extreme sunlight. Make sure that the environment is well lit. The entire track must be visible from the stopping places.
- 3.** Keep uninstructed persons and domestic pets away from the stairlift. Do not use the stairlift to carry animals or goods. Never use the stairlift with more than one person sitting on it. The stairlift may only be used by adults who have signed the instructed person's declaration. Keep children away from the stairlift. Remove the key after use.
- 4.** Keep limbs and clothing away from moving parts. Make sure that wide or loose clothing cannot become trapped between the chair and, say, the stairs or rail.
- 5.** Ensure a safe position. Always ensure a correct, stable position. Sit right up against the back support, use the armrests and place the feet squarely on the foot rest. Always use the safety belt. Never stand on the stairlift.
- 6.** Take care at all times. Concentrate on the operation of the stairlift.
- 7.** Check for damage. Before use check the lift for external damage. Report unusual noises, such as squeaking and creaking, to your supplier. The lift must comply with all prevailing safety regulations. Do not use the lift if a part is defective.

To prevent accidents, repairs and preventive maintenance must only be carried out by engineers qualified to do so.

The stairlift must not be used in the event of a fire or as a means of escape during a fire.

(only for the installer)

Open stair rails (e.g. banisters) should be closed off so that the lift is not accessible from behind.

The electrical connection must comply with section 4.3 of EN60204-1

8. Check for damage

Before the installation inspect the parts carefully for damage in order to make sure that the lift will function properly. The lift must comply with all prevailing safety regulations. Do not use defective parts; only use original parts.

9. Safety devices

All safety devices must be fitted correctly and may only be removed for maintenance and repair work by qualified service engineers trained to do so.

The product must never be used if the safety devices are incomplete or absent, or have been put out of action or are defective.

The safety devices must be checked regularly to see that they are working correctly and, if necessary, must be repaired immediately.

10. Use and installation in accordance with intended use.

Where necessary use safety equipment such as face and hearing protection, safety shoes and hard hat during assembly and servicing. Only use approved tools.

Before you start the assembly, please check whether the stairs and the environment meet the safety requirements.

MAINTENANCE

Cleaning

Clean the stairlift lift regularly.

Avoid excessive use of water. Clean the seat, back support, armrests and footrest only with a slightly damp cloth. Clean the track regularly with a dry cloth. Do not clean the metal rack. If dirty spots appear on the rail, these can easily be removed with a damp cloth using a mild detergent. In time the track wheels can leave a mark on the rail.

During the first 50 rides of the stairlift scales of paint might fall on the stairs due to running in of the stairlift.

Preventive maintenance

In addition to cleaning your stairlift, periodic preventive maintenance is necessary for long-term correct functioning.

The stairlift must be serviced at least once a year. This service must be carried out by a qualified person. Contact your supplier to conclude a service agreement. If your stair lift runs over more than 2 floors and/or has more than 2 users, it needs at least 2 maintenances a year.

Technical specifications

Supply voltage	230 VAC
Frequency	50/60 Hz
Current	1 A
Power	360 watt
Fuses	30 A
Load (max.)	125 kg
Speed	0.15 m/s (max.)
Ambient temperature	-5 - 35 °C
Relative humidity	20 - 80 %
Service life	15 rides per 24hours 10 rides continuous 56 dB
Noise	

An electrical output socket shall be available to the stairlift for local lighting during inspection and servicing. Lighting to a minimum value of 50 lux shall be provided at the boarding points whilst the stairlift is in use.

All rights reserved. No part of this publication may be reproduced and/or published by means of print, photocopy, microfilm or in any other way or form, without prior written permission from the manufacturer. This also applies for the accompanying drawings and diagrams. the manufacturer reserves the right to change parts at any time, without prior or direct notification to the customer. The contents of this manual can also be changed without prior warning. This manual is intended for the standard model of the lift. the manufacturer therefore cannot be held liable for any damage resulting from specifications which differ from those of the standard model of the lift supplied to you. For information concerning adjustment, maintenance or repairs not provided in this manual, you are asked to contact the technical department of your supplier.

This manual has been compiled with every possible care but the manufacturer cannot accept responsibility for any errors in this manual or for the consequences thereof.

The Dutch manual is the original language

FAULTFINDING

OBSTACLE _____ page 21

CHAIRPOSITION _____ page 22

EMERGENCY STOP _____ page 22

ARMREST _____ page 23

KEY _____ page 23

BATTERIES RC _____ page 24

POWER _____ page 24

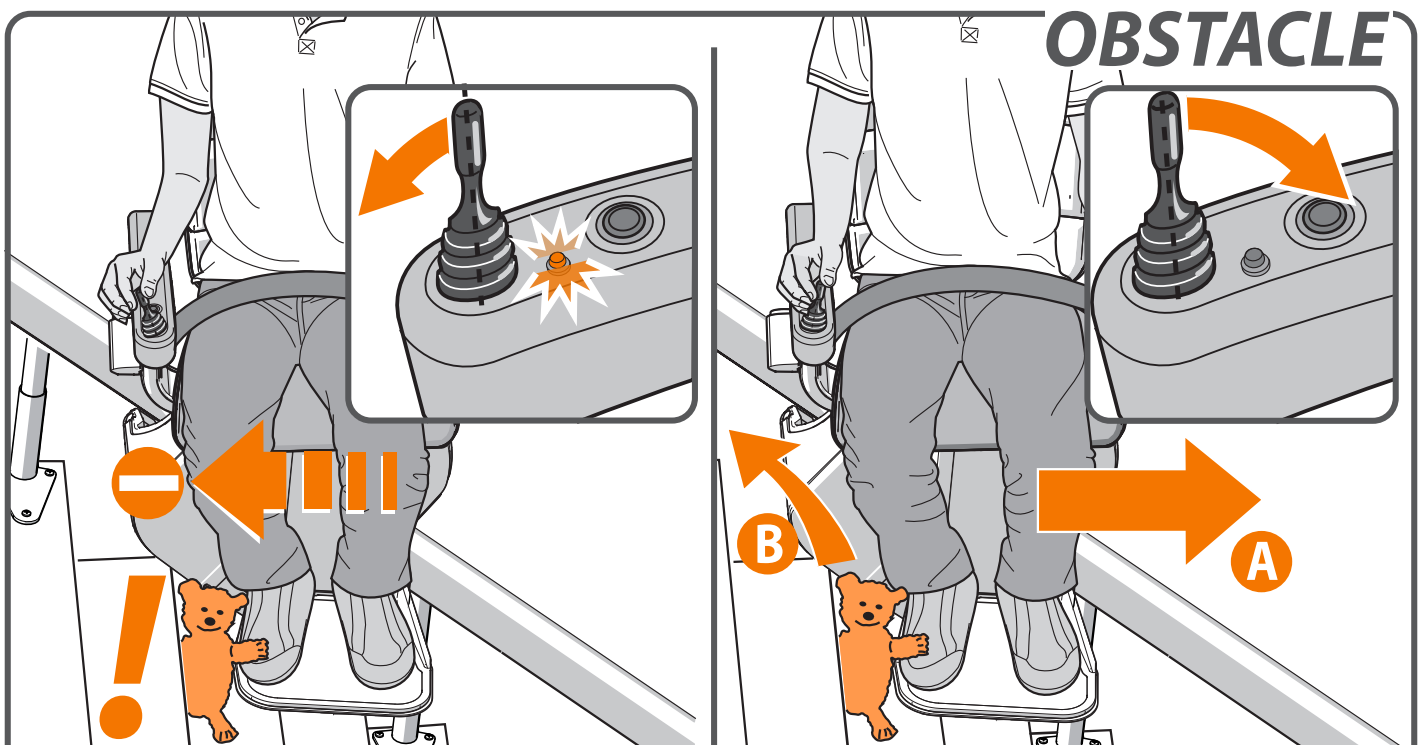

CAUSE

SOLUTION

Problem: the lift travels in one direction only and the LED flashes when the joystick is operated.

Cause: there is an obstacle between the lift and the stairs.

Solution: move the lift in the opposite direction {A} and remove the obstacle {B}.

CHAIRPOSITION

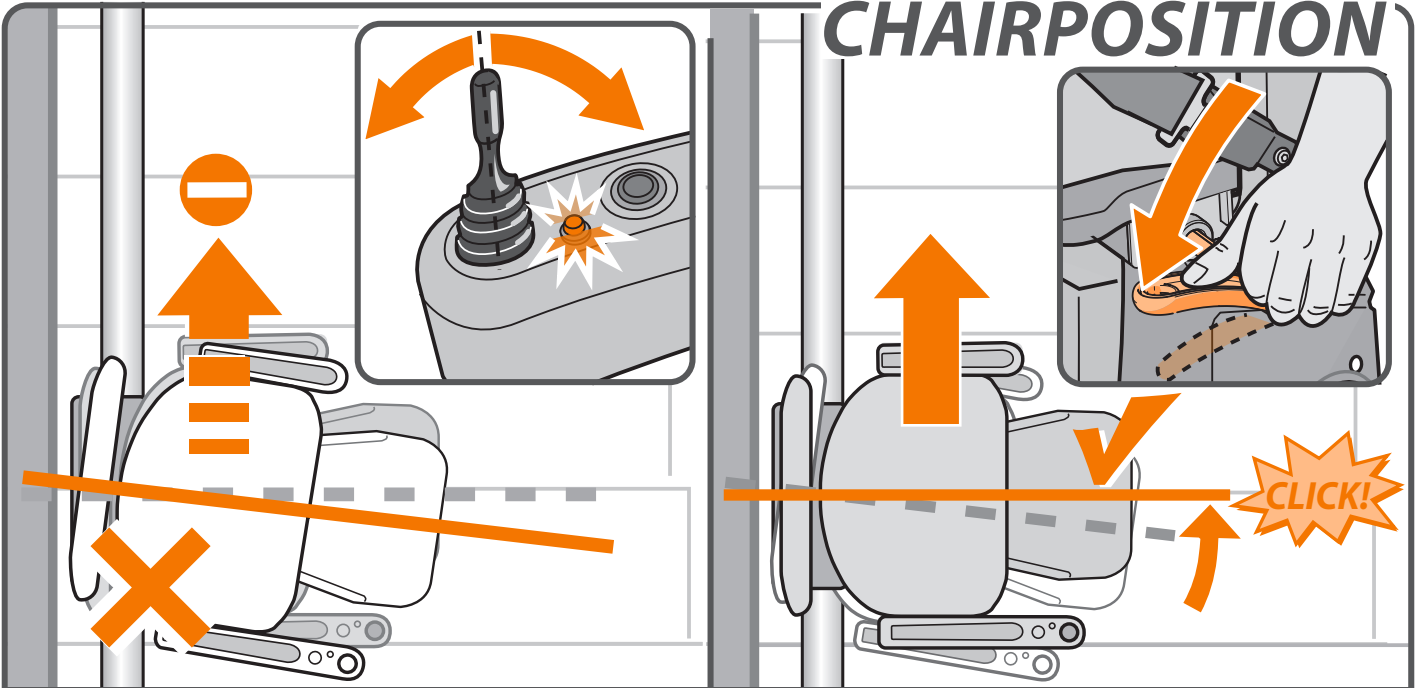

CAUSE

SOLUTION

Problem: the lift does not travel in either direction and the LED flashes when the joystick is operated.

Cause: the seat is not locked and is in a swivelled position.

Solution: swivel the seat using the handle located to the left or right under the seat.

EMERGENCY STOP



CAUSE

SOLUTION

Problem: the lift does not travel in either direction, the LED[1] flashes when the joystick is operated and the emergency stop [2] is illuminated.

Cause: the emergency stop has been pressed.

Solution: press the emergency stop once.

ARMREST

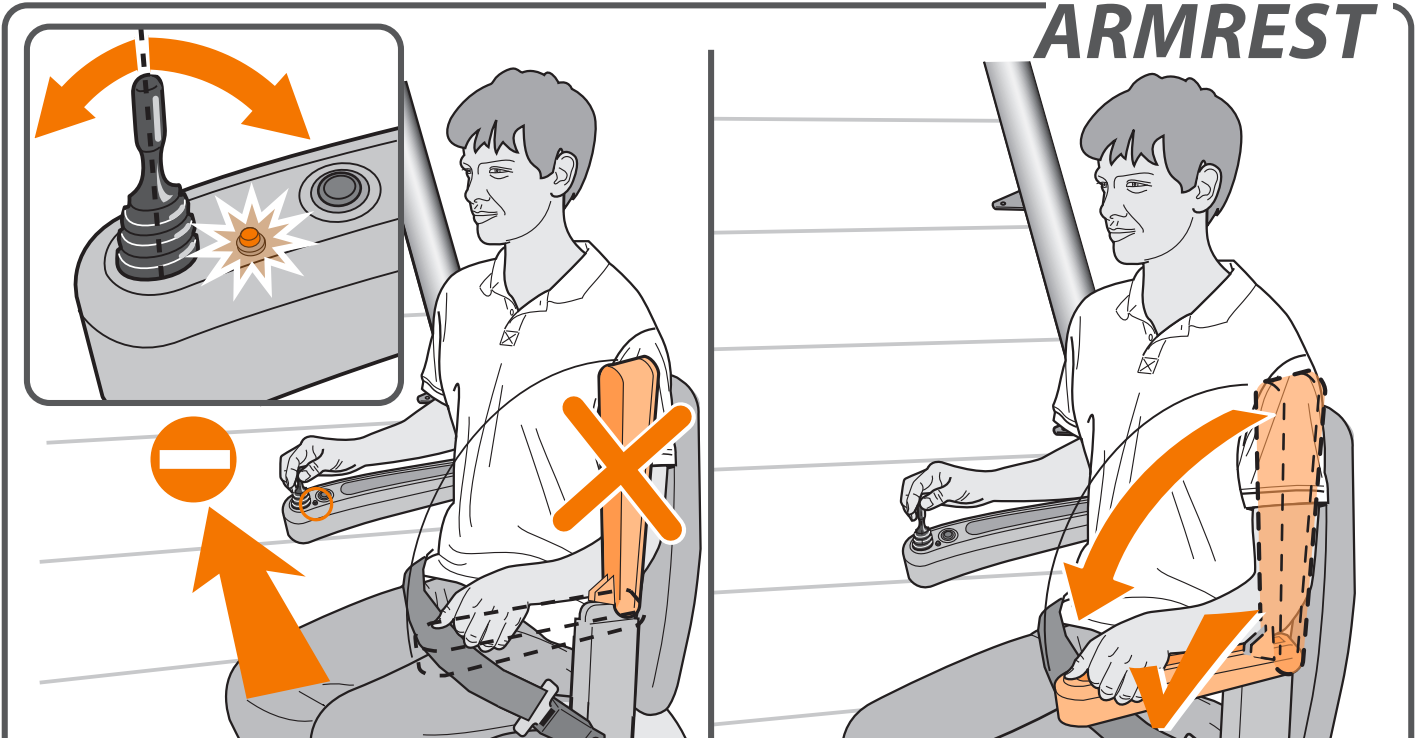

CAUSE

SOLUTION

Problem: the lift does not travel in either direction and the LED on the armrest lights up when the joystick is operated. **Cause:** an armrest has not been folded down. **Solution:** fold down the armrest fully.

KEY



CAUSE

SOLUTION

Problem: the lift does not travel in either direction and the LED on the armrest does not light up when the joystick is operated.

Cause: the key-operated switch is in the off position.

Solution: turn the key-operated switch ninety degrees clockwise.

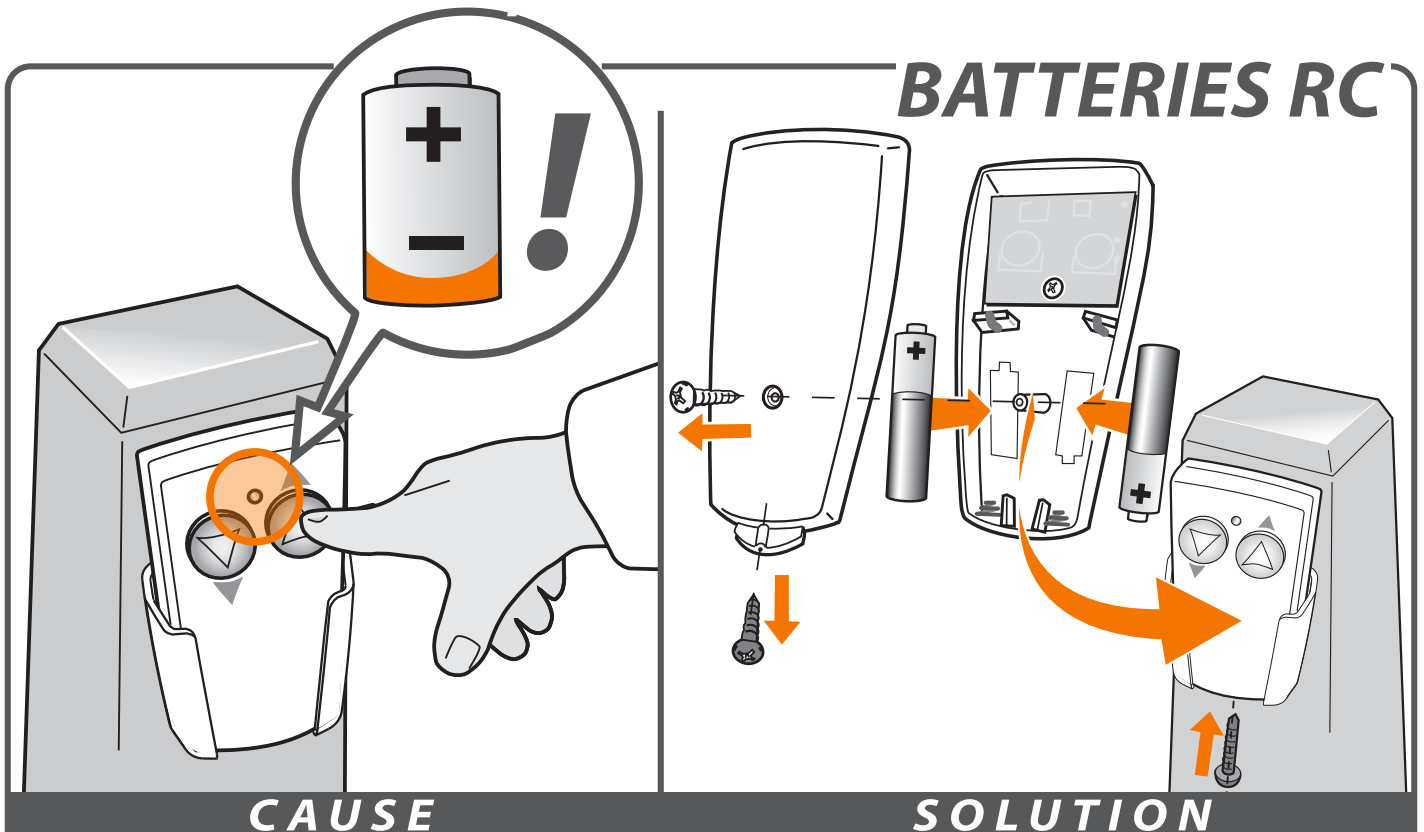

BATTERIES RC

CAUSE

SOLUTION

Problem: the lift does not travel in either direction and the LED on the remote control does not light up when the remote control is operated.

Cause: the batteries in the remote control are flat.

Solution: replace the batteries in the remote control.

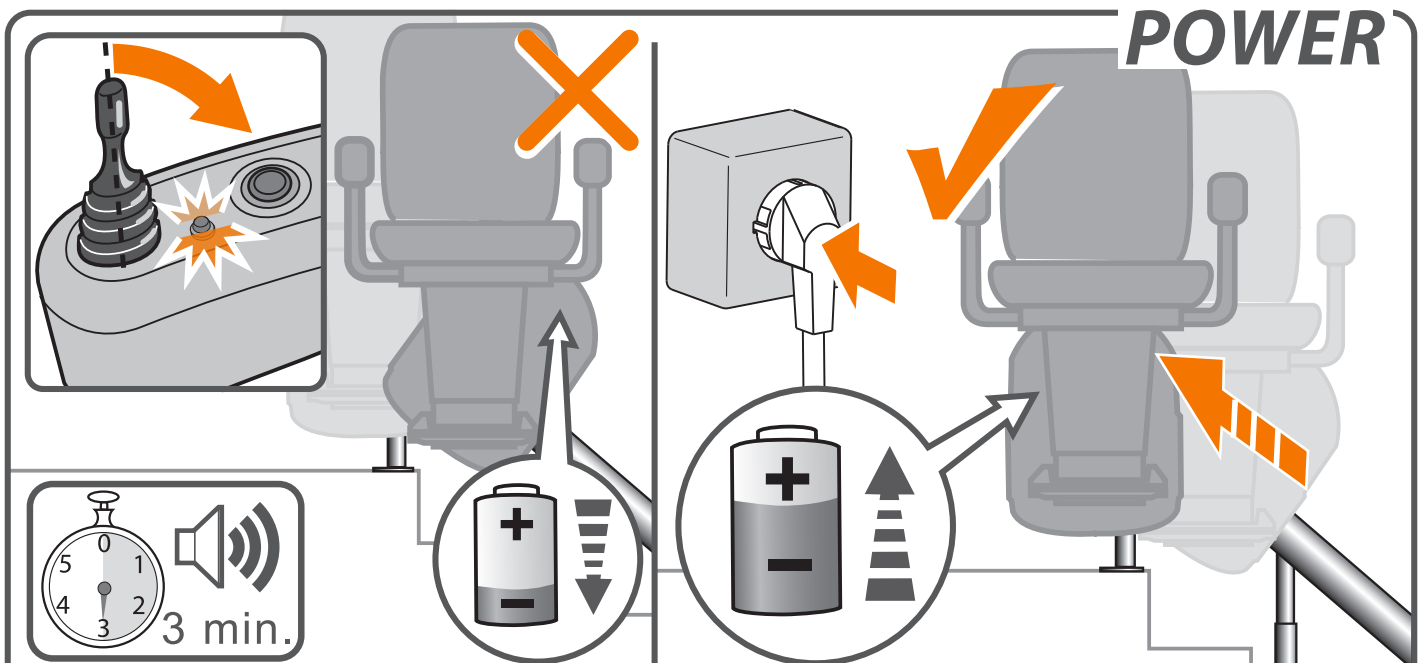

POWER

CAUSE

SOLUTION

Problem: the lift batteries are not recharging, the LED is flashing and the lift beeps for three minutes.

Cause: the lift is not in the correct position at a charge point or the plug is not in the socket.

Solution: move the lift to a charge point or put the plug in the socket.

ATTACHMENTS

REMINDERS _____ *page 25*

REMOTE CONTROL _____ *page 26*

TAP 2 FLOOR _____ *page 27*

VOICECONNECT _____ *page 28*

SPAREPARTS _____ *page 29*

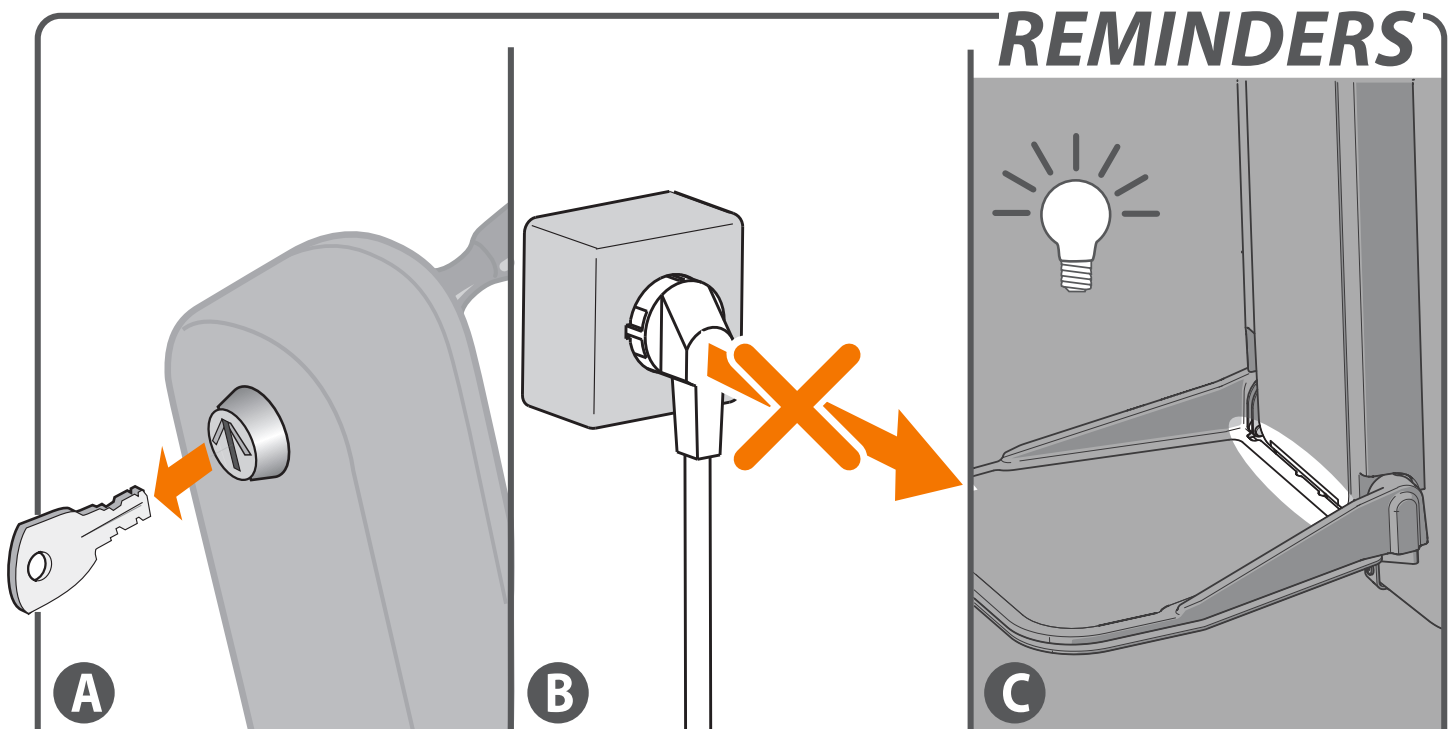

REMINDERS

[A] Remove the key from the switch whenever you leave the lift.

[B] Never remove the lift plug from the wall socket.

[C] The powered footplate has a light, which goes off automatically when the footplate is folded up or when the lift is not at a charge point.

REMOTE CONTROL

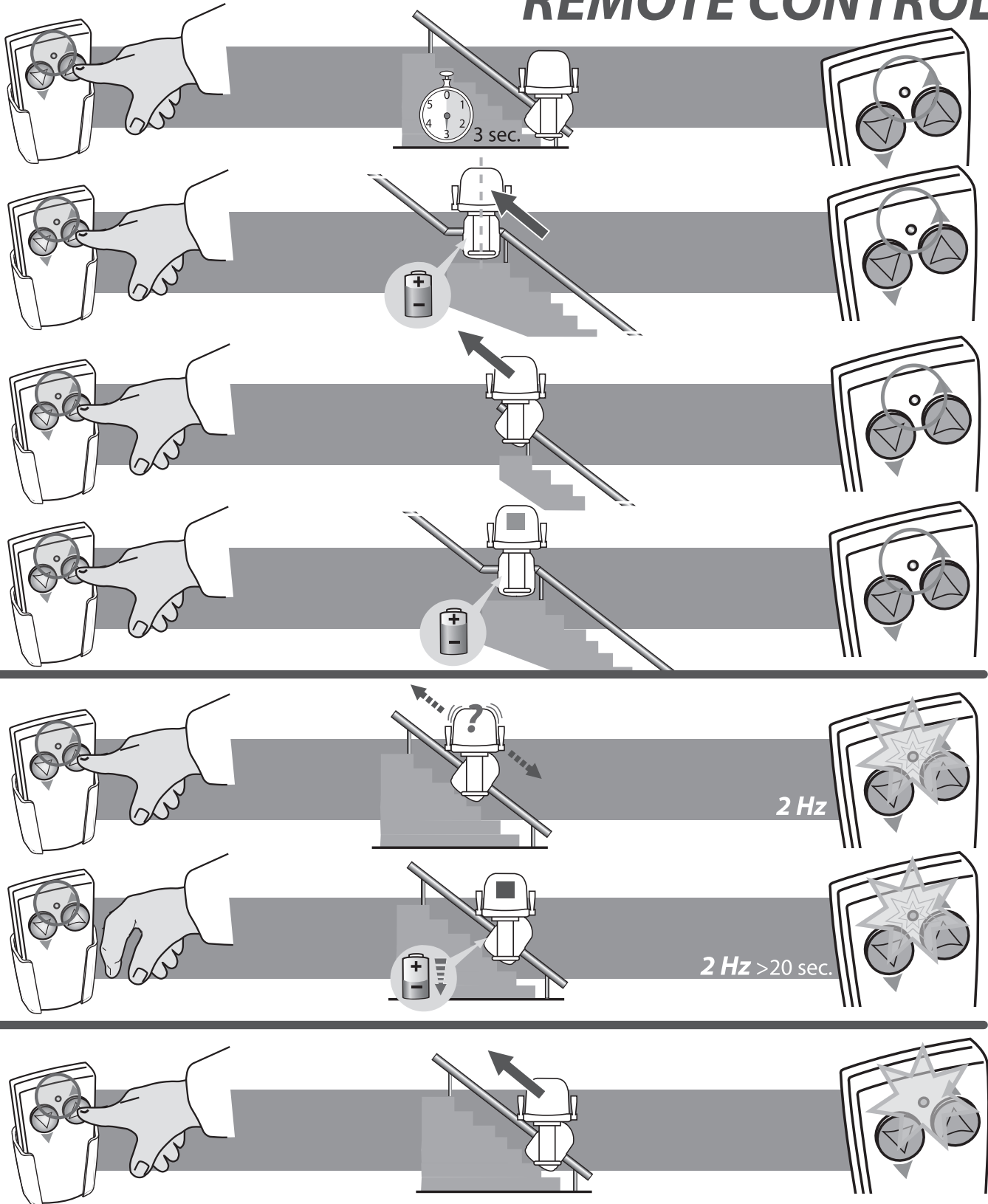

Operation	Situation	LED
when using remote control	stairlift in start-up phase (3 sec)	LED remains off
when using remote control	stairlift travelling	LED turns on
when using remote control	stairlift stopped at an active charging station	LED turns off
when using remote control	stairlift is stopped at the end stop and will not depart until it is called in the correct direction	LED remains off
when using remote control	stairlift is out-of-order and can no longer depart	LED flashes twice a second
when not using remote control	stairlift stopped at an active charging station	LED off
when not using remote control	stairlift is stationary en route, i.e. not at a charging station	LED flashes twice a second for 20 seconds after operation has stopped. LED then turns off

TAP 2 FLOOR

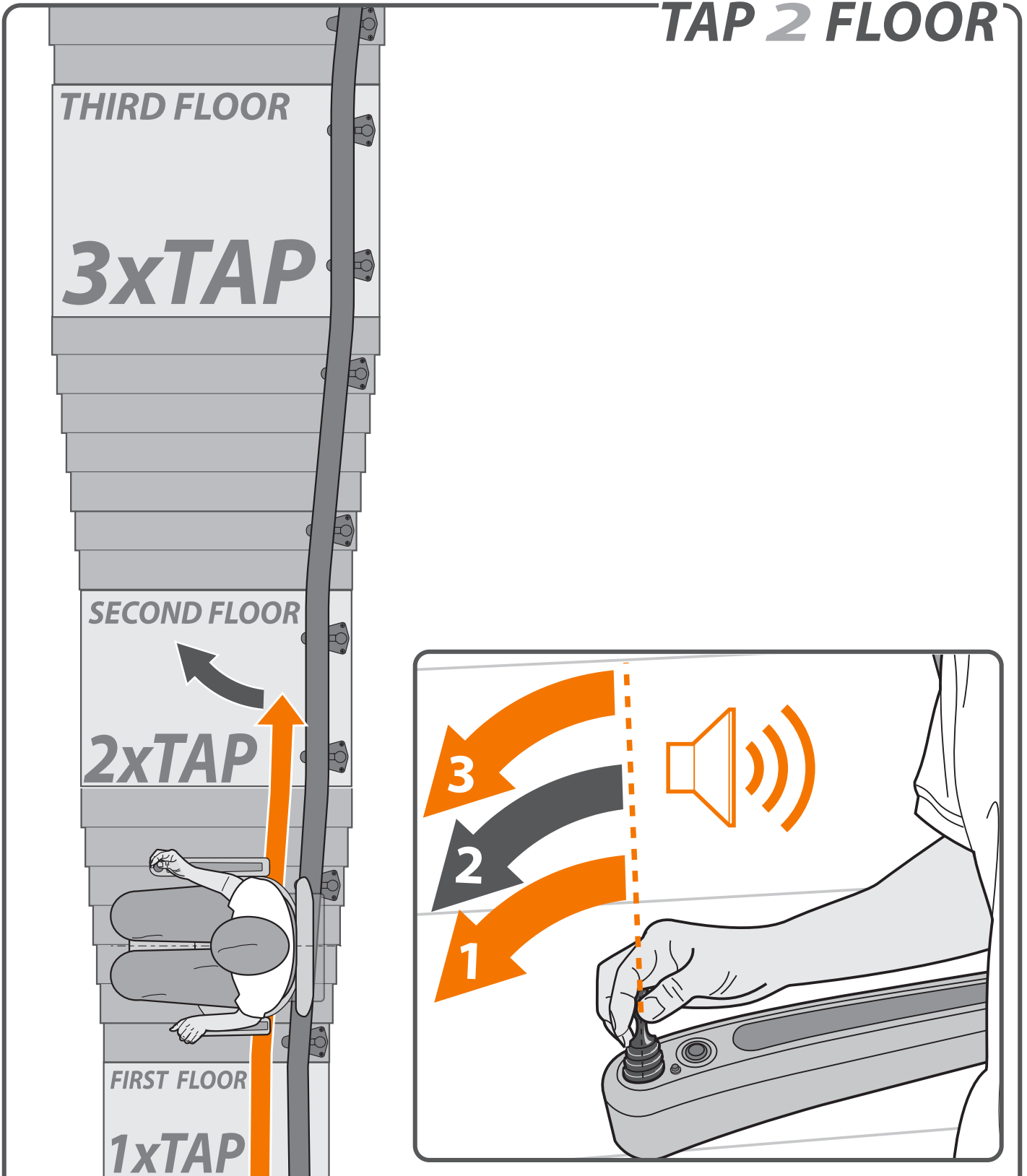

Stairlift with powered swivel can swivel automatic on a preferent intermediate landing after tapping. Before the start of the lift, the joystick (not the remote control) is operated in the direction of travel (Tap). The number of operations (taps) indicates the desired floor. Tapping must be done rather quickly. After each tap you hear a beeping sound. LAST press (when holding the joystick to start driving) is NOT counted as a tap !!

VOICECONNECT

A safe feeling

11P00376

Please keep a record of contact names and telephone number.

*Hi, it's me.
I don't feel well.
Can you help me?*

tel. 1:

tel. 2:

tel. 3:

*Don't worry,
I'll be there
in a minute*



#1 _____



#2 _____



#3 _____



Record of contact names

7A

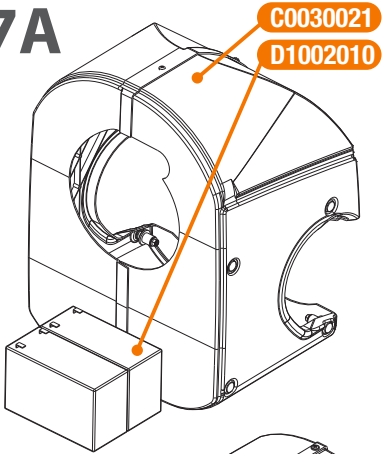

12A

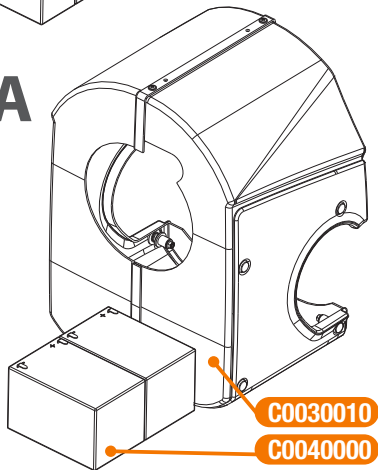

E0005100
E0005200
E0006100
C3020900

C3020010
C1001413

C1001513
SP000800 (USA)

C0020310

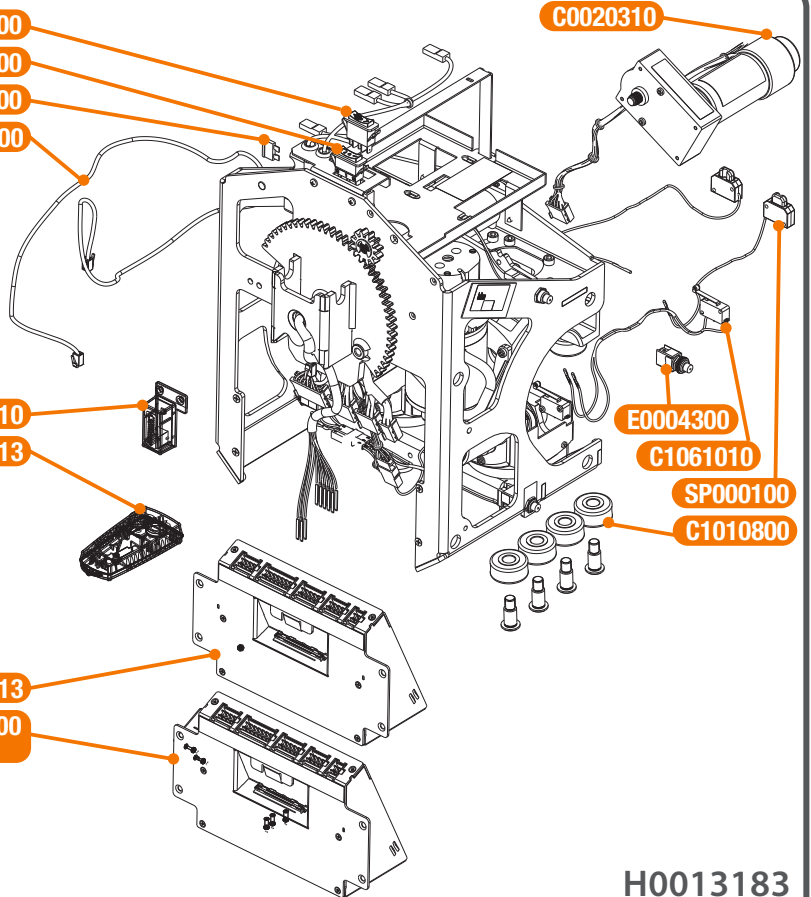

H0013183

FR095410

FR093100

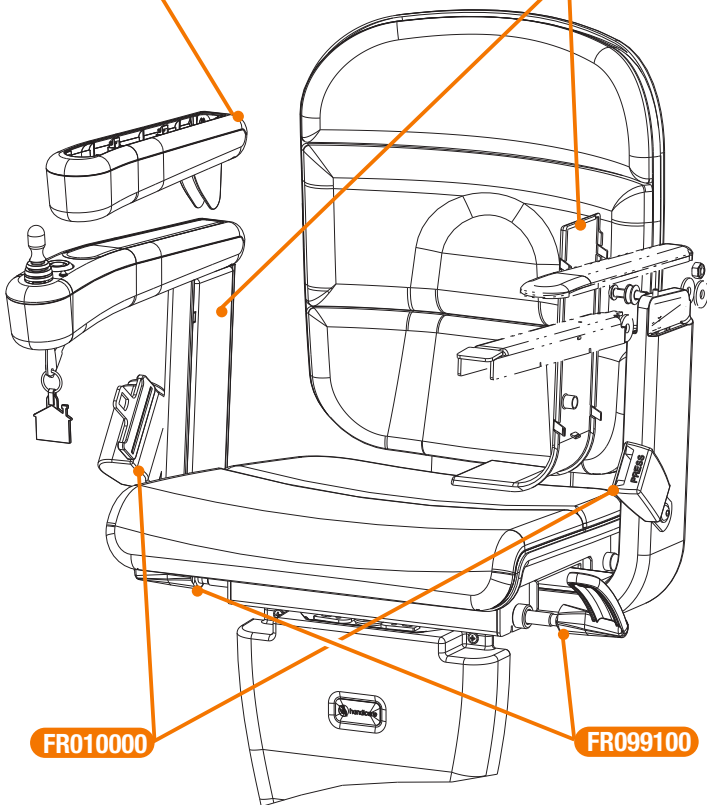

H0013194

B5030120
11K00014

C3002100

B0020500

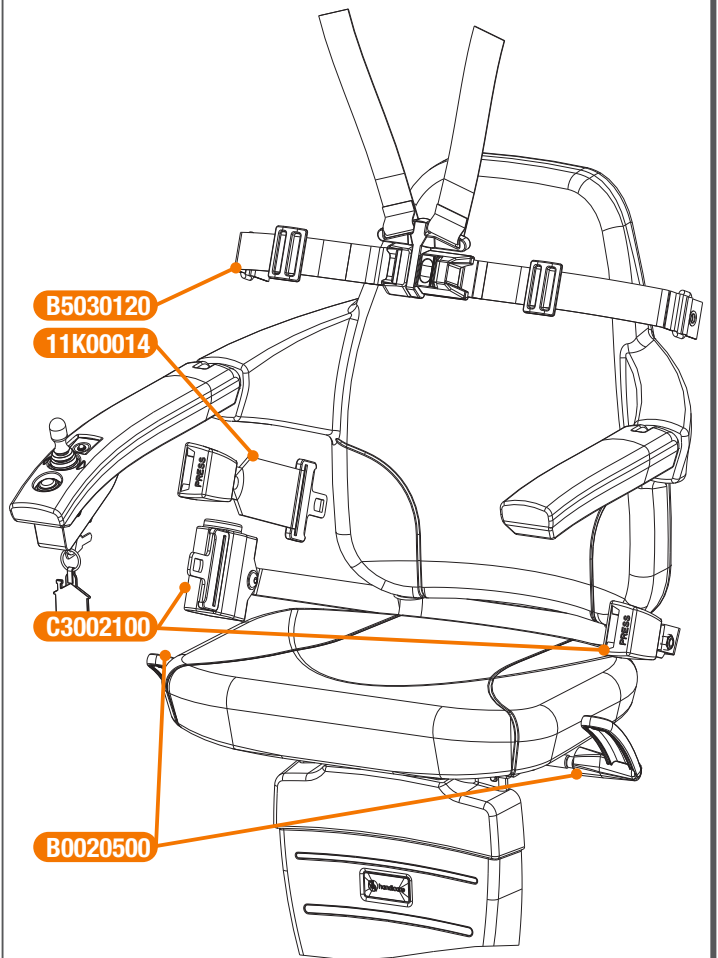

H0013191



handicare

Handicare Stairlifts B.V

Newtonstraat 35
1704 SB Heerhugowaard
The Netherlands
T +31 (0)72 576 88 88
F +31 (0)72 574 34 35
stairlifts@handicare.com
www.handicare.com

Handicare Accessibility Ltd

82 First Avenue, Pensnett Estate
Kingswinford, West Midlands
DY6 7FJ United Kingdom
T. +44 (0)1384 408700
F. +44 (0)1384 408719
E. enquiries@handicare.co.uk

Handicare

2201 Hangar Place
Suite 200
Allentown, PA 18109
United States of America
Toll free: (866) 276-5438
Local: (610) 266-5260
Fax: (610) 266-5266
info@handicareusa.com

Handicare Monte-escaliers

ZI de la Croix Blanche
20 Avenue Scotte
91700 Ste Genevieve des Bois
France
Tl. : +33 (0)1.69.46.86.10
Fax : +33 (0)1.69.46.86.19
monteescaliers@handicare.fr

Handicare GmbH

Hausberger Straße 16
32457 Porta Westfalica
Deutschland
Tel: +49 (0) 571 973398-55
Fax: +49 (0) 571 973398-56
data@handicare.com

USER MANUAL



11P00388, rev.B